



Electric Wine Preserver



EP-VACSEAL2

OWNER'S MANUAL

EPICUREANIST WINE PRESERVER

The Epicureanist Wine Preserver combines style with functionality, while vacuum sealing your wine bottles to keep wine fresh. It is rechargeable and is designed to fit most standard 750ml wine bottles. Preserver comes with two reusable bottle stoppers.

PLEASE READ ALL INSTRUCTIONS BEFORE USE

-SAVE INSTRUCTIONS-

IMPORTANT SAFETY INSTRUCTIONS

- Do not use this device for other than its intended purpose.
- Exercise caution and use reasonable supervision when device is used near children. Never allow children to operate or play with unit.
- Intended for indoor household use only.
- Locate the unit away from direct flames and other sources of heat (stove, heater, radiator, etc).
- Do not immerse in water or other liquids. Avoid locating the unit in moist areas.
- For safety and best results, do not operate unit in an ambient temperature outside the range of 32°-95°F.
- When charging the unit, always attach plug to the unit first, then connect cord into the wall outlet.
- If unit malfunctions due to damaged cord or plug, do not operate. Return it to the service center or a qualified person for examination or repair.

WARNING: Do not use the unit as a handle to lift or move the bottle. This may cause the bottle to fall from the appliance.

WINE PRESERVER DIAGRAM

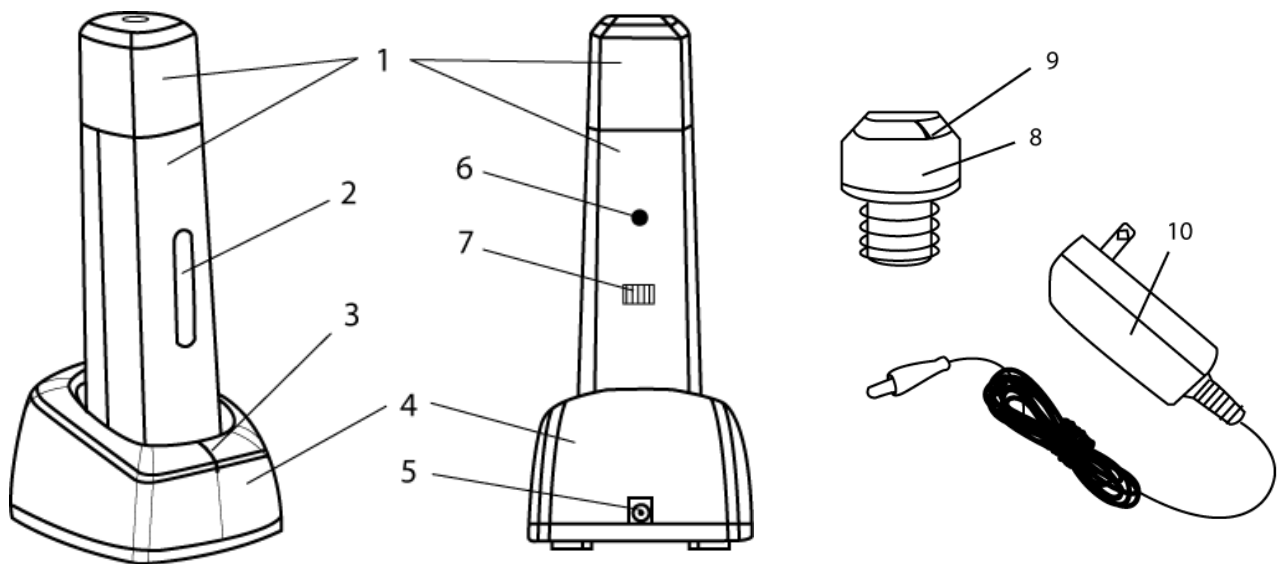

- | | | | |
|----|----------------------|-----|------------------------|
| 1. | Wine preserver Body | 6. | Rear Screw |
| 2. | Power Button | 7. | Air Outlet |
| 3. | LED Indication Light | 8. | Wine Stopper |
| 4. | Charging Base | 9. | Wine Stopper Date Dial |
| 5. | DC In | 10. | AC/DC Adapter |

CHARGING YOUR WINE PRESERVER

Unit requires 12 hour charge before first use. One full charge will allow the wine preserver to vacuum seal approximately 30 standard bottles. To charge:

- Plug D/C connector into unit, then plug A/C end into electrical outlet.
- Place wine preserver into charging base properly to initiate charge.
- Charging base will start working automatically and the indicator light will turn red while charging.
- When the charging process is complete, indicator light will turn green and the sealing system is fully charged and ready.

SEALING THE WINE BOTTLE

- Place a wine stopper on the wine bottle.
- Press the wine preserver onto the stopper gently, ensuring a good fit.
- Press the power button on the wine preserver to begin the sealing process. The power button will turn blue to signal that sealing is in progress.
- The wine preserver will shut off automatically when sealing is complete.
- Remove the wine preserver from the stopper and set the date dial to reflect date of preserving seal.

REMOVING THE SEAL

- To remove the seal, pull the stopper from the bottle by hand.

CARE AND MAINTENANCE

- Always store your Electric Wine Preserver in a cool, dry place.
- Always disconnect before cleaning.
- To clean, wipe housing with a soft and dry cloth. Do not use liquid or abrasive cleaning agents.

TROUBLESHOOTING

Try the suggestions below to see if you can solve the problem before contacting Epicureanist at info@epicureanist.com

PROBLEM	POSSIBLE CAUSE
LED indicator light does not work	<ul style="list-style-type: none">• Check if the DC cord is in good condition• Check if the electrical outlet is in good condition• Check if the plug is connected properly• Check if the charging base has been damaged
Wine Preserver does not work	<ul style="list-style-type: none">• Check if wine preserver needs to be recharged• Check if wine preserver has been damaged
Air Leakage	<ul style="list-style-type: none">• To Test Pump: Seal and vacuum bottle, then pull stopper out vertically. If you do not hear a “pop”, the pump is malfunctioning.• To Test Stopper: Seal and vacuum bottle, wait 4 hours, then pull stopper out vertically. If you do not hear a “pop”, the stopper is malfunctioning.

IMPORTANT DISPOSAL INSTRUCTIONS

As a responsible company, we care about the environment.

As such, we urge you to follow the correct disposal procedures for your product, batteries, and packaging materials. This will help conserve natural resources and ensure that it is recycled in a manner that protects health and the environment.

You must dispose of this product and its packaging according to local laws and regulations. Because this product contains electronic components and sometimes batteries, the product and its accessories must be disposed of separately from household waste when the product reaches its end of life cycle.

The product and batteries should be taken to a proper recycling/disposal facility.



TERMS OF SALE & WARRANTY

Epicureanist LLC ("Seller") and the person or entity that acquires these goods from Seller ("Purchaser") hereby fully agree to the following terms and conditions of the sale: Shipping fees are the responsibility of the Purchaser whether freight prepaid or freight collect. Seller assumes no responsibility for the goods sold to the Purchaser once the goods have left the Seller's premises, including, but not limited to, late delivery by the moving carrier, or for events caused by any difficulty carrier incurs in attempting to fit the goods into the Purchaser's place of business or residence due to the size of the goods or otherwise. Purchaser assumes all responsibility for delivery, payment of freight, access, measurement, installation, hook-up, wiring, moving and storage of the goods. The transportation of all goods is subject to the terms and conditions which the moving carrier imposes on Purchaser including, but not limited to, additional charges imposed per flight of stairs, and/or additional charges resulting from the carrier's inability to safely and/or adequately use the building elevator to lift the goods to an upper floor. Any claim for damages incurred during shipment by the carrier of the goods are insured and handled directly with the carrier and must be noted at time of delivery. Any damages due to manufacture defects will be handled directly with Epicureanist, subject to the limited warranty.

All sales are final, and unless authorized in writing by the Seller, Purchaser may not return the goods, under any circumstance. If Purchaser refuses to accept the goods, under any circumstance, the Purchaser is liable for the return and cost of freight both ways, and if Seller does take back the goods, there will be a restocking/service fee that is 35% of the purchase price of the goods. Built-to-Order products (including Cabinets, Racking, and Accessories) are non-returnable. Purchaser must notify Seller of non-conforming goods within four days of delivery, after which time all goods are deemed accepted. If an order has been placed and production has started, cancellation of your order will be a 15% charge.

If Purchaser tenders payment with a check that has insufficient funds (NSF), or stops payment on a check or credit card for any reason, Purchaser agrees to pay for all costs associated with the Seller's connection or litigation of such a claim, including without limitation extra damages, court costs and attorneys' fees. Finance charges begin the date of invoice. Collection fees plus NSF fee of \$50 will be added to your invoice, which you agree to promptly pay. Title to the goods does not pass until payment is received in full by Seller and Seller retains a security interest in the goods until they are paid for in full.

LIMITED WARRANTY: Seller warrants that the goods will be free of defects in materials and workmanship as follows: Furniture style (wood) wine units: all cooling unit parts for a period of 5 (five) years; cabinetry and labor (uninstalled) for a period of 12 (twelve) months from date of sale. For the metal cabinet wine units: parts and labor for cooling system and cabinetry for a period of 12 (twelve) months from date of sale. Thermoelectric Units: 90 (ninety) days from the date of sale. (This includes Wine Coolers, Beer Dispensers, Humidor, Portofino Wood Cellars, and Refrigerators). Wine-Mate Split Systems and installed products are parts only for 1 year, no labor. Other Wine-Mate Cooling Systems are 5 years parts, 1 year labor. Element Grills (via Element Products LLC) have a 1-year comprehensive parts warranty on entire product. Three years limited parts warranty covering the stainless burner and a thirty day limited parts warranty on grill accessories. Wine Accessories and Racking Systems are not warranted. For a scratch and dent/refurbished unit, warranty is 3 months from your dated invoice (parts for function only, not cosmetic). There is no warranty on parts purchased separately. Removal and re-installation of unit is not included in warranted labor. Purchaser's exclusive remedy is limited, at Seller's option; to repair or replace defective part[s] with either new or factory reconditioned part[s]. Purchaser is responsible for shipping the unit pre-paid to designated facility and Seller will pay return shipping charges in the continental United States for items repaired under warranty within 12 (twelve) months from date of sale. Since the natural variation in texture, density, grain, color, tone and shade of wood is unavoidable; Seller does not guarantee the texture, color, tone or shade of the wood: nor does seller guarantee the colorfastness of wood or against peeling, chipping, cracking or scratching. Note: Unfinished wood is subject to warping; all wood surfaces must be sealed before placing cellar into service. Improper placement of the unit will void the warranty. This limited warranty does not cover damage due to such things as accident, misuse, abuse, mishandling, neglect, acts of God, fires, earthquakes, floods, high winds, government, war, riot or labor trouble, strikes, lockouts, delay of carrier, unauthorized repair, or any other cause beyond the control of the Seller, whether similar or dissimilar to the foregoing. Seller is not responsible for any damages caused to Seller's property resulting from the good. This limited warranty applies only inside the Continental US. (Alaska, Puerto Rico and Hawaii are not warranted.)

For Element/Fuego Grills, warranty is 1 year, with 3 years on the burner. If grill is defective and unused plus all packaging and parts are intact, we will either replace the grill or provide service to repair the grill. Returned product must accompany all original packaging and parts and is subject to our 35% restocking fee (and freight both ways).

With Wine-Mate products, if the customer calls and the product is "defective", you must obtain a letter from your qualified refrigeration technician at the customers cost, to verify that the unit was installed properly, with proper ventilation and the unit is truly malfunctioning due to manufacture defect.

Purchaser understands and acknowledges that the goods sold here are wine cellars, cigar humidors, and/or other similar units which house wine or cigars. Purchaser assumes all risk of using these units, including risk of spoilage, humidity variations, temperature variations, leaks, fire, water damage, mold, mildew, dryness and similar and any other perils that might occur.

Seller is not responsible for incidental or consequential damages, and there are no warranties, expressed or implied, which extend beyond the Limited Warranty described above. The implied warranties of merchantability and of fitness for a particular purpose are hereby expressly disclaimed. Some states do not allow the exclusion of incidental or consequential damages, or a waiver of the implied warranties of fitness and/or merchantability, so the above limitations may not apply to you. This warranty gives you specific legal rights and you may also have other rights which vary from state to state. Seller disclaims any indemnification for claims of infringement of any intellectual property of protectable nature.

In the event of any dispute between Seller and Purchaser arising out of or relating to these terms and conditions or to the goods sold generally, Purchaser must first file a written claim with Seller within ten days of the occurrence giving rise to the claim and wait an additional thirty days for a response before initiating any legal action. The sale and all terms are subject to California law. Any legal proceeding arising out of or relating to these terms and conditions or to the goods sold generally shall be brought solely and exclusively in the County of Los Angeles. In no event may Purchaser initiate any legal proceeding more than six months after the occurrence of the event giving rise to the dispute.

The above terms and conditions are the only ones governing this transaction and Seller makes no oral representations of any kind. These Terms and Conditions can only be modified in writing, signed by both Purchaser and Seller. 11/11

Contact info@epicureanist.com with any questions or visit
www.epicureanist.com



Costa Mesa, CA 92627
www.epicureanist.com

SERVICE & IMPORTANT NOTICE:

The manufacturer has a policy of continuous improvement on its products and reserves the right to change materials and specifications without notice.

WARNING:

**Please do not place the unit within reach of children.
For adult use only.**

Epicureanist is a trademark of Epicureanist LLC. All products, features, and services are subject to change without notice. We cannot guarantee the accuracy of the contents of this document. We disclaim liability for errors, omissions, or future changes.

©2012 Epicureanist LLC. All rights reserved.