



www.winemate.com

WINE-MATE Split System

Installation, Operation & Care Manual

VINO2500SSV VINO4500SSV VINO6500SSV



Vinotemp

Vinotemp International Corp.

www.vinotemp.com

READ AND SAVE THESE INSTRUCTIONS

TABLE OF CONTENTS

Important Safety Information.....	2
Features & Specifications.....	3
Cellar Construction.....	7
Installer’s Instruction.....	8
Electrical Wiring.....	15
Temperature Control & Humidity Adjustment.....	19
Care Guide.....	22
User’ Troubleshooting.....	23
Customer Support.....	25
Warranty.....	26

Important Safety Information

WARNING



To avoid the risk of electrical shock, property damage, personal injury or death:

- The power cord must be plugged into a 3-prong grounding-type wall receptacle, grounded in accordance with the National Electrical Code, ANSI/NFPA 70 - latest edition and local codes and ordinances.
- It is the personal responsibility of the consumer to have a proper 3-prong wall receptacle installed by a qualified electrician.
- **DO NOT, UNDER ANY CIRCUMSTANCES, REMOVE THE POWER CORD GROUNDING PRONG.**
- A separate adequately fused and grounded circuit should be available for this appliance.
- Do not remove any grounding wires from individual components while servicing, unless the component is to be removed and replaced. *It is extremely important to replace all grounding wires when components are replaced.*

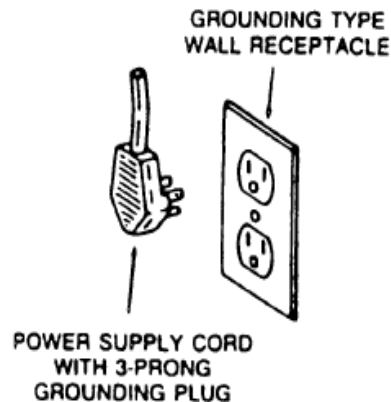

WARNING



ELECTRIC SHOCK HAZARD

- Disconnect electric supply from appliance before servicing.
- Replace all panels before operating.
- Failure to do so could result in death or electrical shock.

WARNING:

- **DO NOT USE A GROUND FAULT INTERRUPTER (GFI).**
- **A DEDICATED 20 OR 30 AMP CIRCUIT IS REQUIRED (2500-4500SSV OR 6500SSV).**

Features and Specifications

- Wine-Mate split cooling systems VINO2500-6500SSV are designed and used to provide a cold temperature between 50~65 °F for a properly insulated wine room at a normal environment.
- The wine room will maintain humidity of 50~70% RH even when the environment becomes dry and humid. These temperatures and humidities are optimized for long term storage of wine.
- SSV units consist of a condensing unit and an evaporator unit, and they are connected by a liquid line and an insulated suction line.
- SSV condensing units can be located away from the evaporator units and wine cellars as far as 50 ft, which will bring you quiet operation.
- The SSV evaporator units are designed for installation in a wine rack or inside a wine room corner, making them an ideal choice for small and medium wine rooms. There are also multiple air inlet and outlet doors for different installations.

The dimensions and capacities are specified as follows:

MODEL	EVAP UNIT	COND UNIT L"xD"xH"	Btu/h, CFM (55/90°F)	CAPACITY (55/75°F)	REFRIGERANT	ELECTRICAL EVAP UNIT/ COND UNIT	WEIGHT(lb) EVAP UNIT/ COND UNIT
VINO-2500SSV	WM-25SFCV	WM-250SCU 18x12x14	2500/220	250 cu ft	R134a	115V-60HZ- 0.77A / 115V- 60HZ-5.7A	48/40
VINO-4500SSV	WM-45SFCV	WM-450SCU 18x12x14	4500/335	1000 cu ft	R134a	115V-60HZ- 0.77A / 115V- 60HZ-6.9A	59/60
VINO-6500SSV	WM-65SFCV	WM-650SCU 24x18 x17	6500/420	1500 cu ft	R134a	115V-60HZ- 1.9A / 115V- 60HZ-12A	63/60

EVAP UNIT	A	B	C	D
WM-25SFCV	41 1/2	13	8 13/16	8 7/16
WM-45SFCV	47 1/2	16	9 5/16	13 15/16
WM-65SFCV	51 1/2	18	N/A	N/A

NOTE:

CAPACITY IS DETERMINED UNDER THE CELLAR AND AMBIENT TEMPERATURES OF 55°F AND 75°F WITH R11 INTERIOR AND R19 EXTERIOR INSULATIONS. ANY LOWER CABINET AND HIGHER AMBIENT TEMPERATURES WILL REDUCE THE CAPACITY.

CAUTION:

LOW AMBIENT TEMPERATURE KIT IS REQUIRED IF THE INSTALLATION AREA WILL BE BELOW 50°F.

CAUTION:

LIQUID AND SUCTION LINES MAY DIFFER FROM WHAT ARE SHOWN HERE, PLEASE CHECK ON THE UNITS FOR PROPER INSTALLATION.

NOTE:
LEAVE MINIMUM 3" CLEARANCE FOR ELECTRICAL WIRING AND REFRIGERATION PIPING.

Parts included:

Condensing Unit (discharge and suction valves installed) + Liquid Filter + Liquid Indicator

Evaporator Unit (liquid line solenoid valve and expansion valve installed)

Temperature Controller + Air Sensor

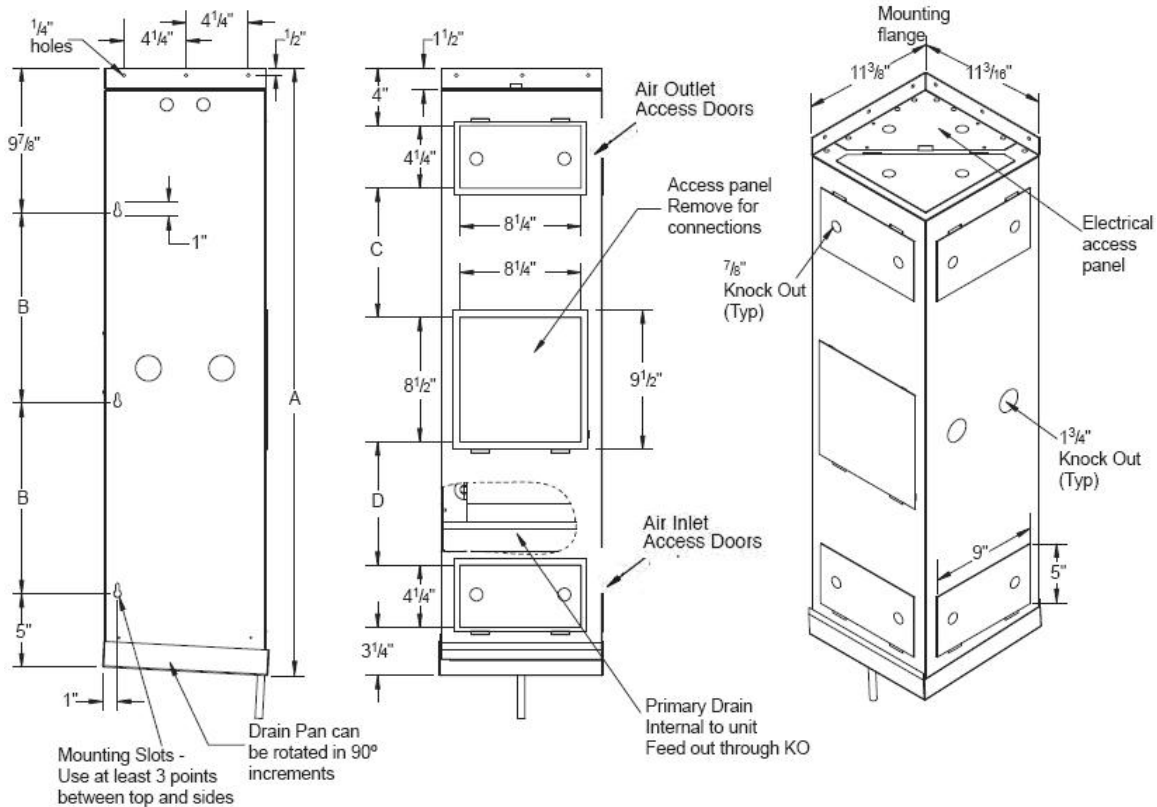

Fig. 1 WM25-65SFCV Evaporator Unit

1. Fresh Air Intake
2. Hot Air Exhaust
3. Liquid Line
4. Suction Line
5. Outdoor Enclosure

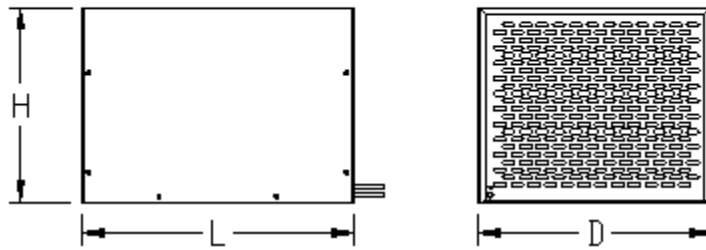
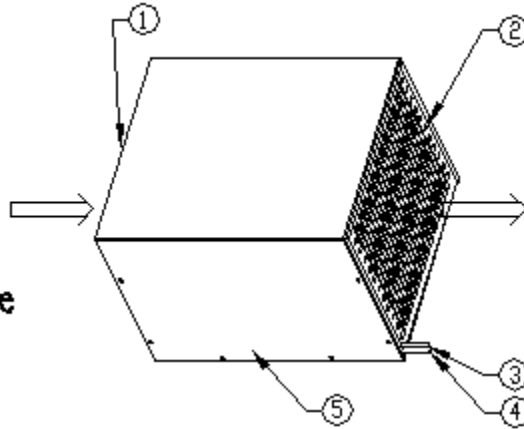

Fig. 2 WM250-450SCU Condensing Unit

1. Fresh Air Intake
2. Hot Air Exhaust
3. Outdoor Enclosure

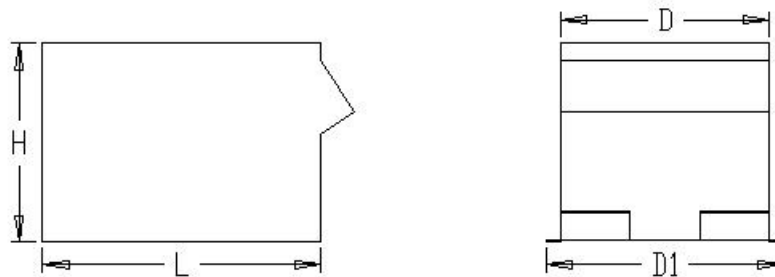
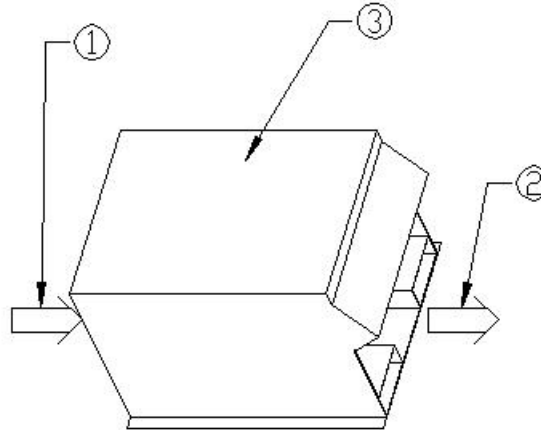

Fig. 3 WM650SCU Condensing Unit

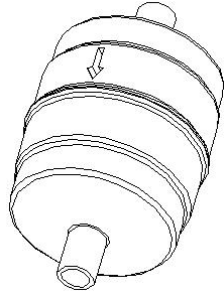

Fig. 4 Liquid Filter

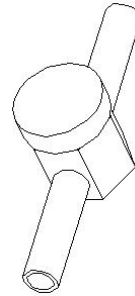

Fig. 5 Liquid Indicator

Cellar Construction

This is only a guide and shall be considered as minimum requirements.

All interior walls and floors shall have a vapor barrier and a minimum of R11 insulation. All exterior walls and ceiling shall have a vapor barrier and a minimum of R19 insulation. The vapor barrier shall be installed on the warm side of the insulation. All joints, door frames, electrical outlets or switches and any pipes or vents that go through the enclosure shall be sealed to prevent air and moisture leakage into the room. Concrete, rock, and brick are not insulation or vapor barriers.



Doors shall be of a minimum size, insulated to at least R11 and tightly sealed with high quality weather stripping. Be sure to seal the bottom of the door and fill gap between the door's frame and wall before installing the cap molding.

In order to maintain 55 °F in the wine cellar, the ambient temperature surrounding the enclosure shall not exceed the temperature of the enclosure by more than 25 °F. No enclosure wall shall receive direct sun or strong wind.

Lighting shall be of low wattage, with a timer to insure lights are not left on when the enclosure is not occupied.

The cooling system will not be able to maintain the proper temperature if fresh moisture-laden air is constantly being introduced to the enclosure. Symptoms of this condition are; unit runs all the time with only a slight reduction in temperature and/or water overflows from the unit. Because of the temperature difference between the inside and outside, very small cracks can allow large amounts of outside air to enter into the enclosure. Please be aware that moisture can pass through solid concrete, paint and wood. Often a newly constructed room contains fresh wood, paint, concrete and other building materials. These materials contain large amounts of moisture. When placed into operation in this type of environment, the system will work harder to remove this extra moisture resulting in increased "run" time.

Installer's Instruction

 WARNING	
	<p>Always check wiring harness connections before initiating any test procedures.</p> <p>Disconnect electric power from the appliance before performing any maintenance or repairs.</p> <p>Voltage checks should be made by inserting meter probes beside the wires in the connector blocks with the electric power source on and the connector block plugged in.</p> <p>Resistance checks should be made on components with the electric power off and the connector block disconnected.</p>

Federal law requires that WINE-MATE split cooling systems be installed by an EPA certified refrigeration technician.

WINE-MATE split system is shipped as components and is ready for use only after a certified refrigeration technician has properly installed, evacuated, charged and tested the system. Proper installation is critical. Vinotemp can only warrant the quality of the components. The installation and proper operation of the system must be warranted by the installer. Installation of the system must be done in accordance with all state and local building and electrical codes.

The condensing unit and evaporator unit are connected by a liquid line and an insulated suction line that are supplied by the installer. These lines must be properly sized for the distance between the two units. After the units and the lines are installed, the system must be pressure tested. If no leaks are found, evacuate and charge system. Refrigerant amount will vary depending on the length of line set.

1. Condensing Unit

- Place the condensing units WM250-650SCU in a properly ventilated location. If it is not, heat exhausted by the condensing unit will build up and the cooling system will not operate properly.
- Condensing unit shall be elevated to avoid possible flooding and shaded from direct sun. It shall not be exposed to temperatures higher than 110 °F or lower than 50 °F (optional low ambient kit available).
- Leave minimum 5 ft clearance for the exhaust side and leave minimum 1 foot clearance for the fresh air intake side.



CAUTION:

IF THE CONDENSING UNIT IS EQUIPPED WITH A LOW AMBIENT CONDITION KIT, DO NOT TURN ON THE COMPRESSOR UNTIL THE CONDENSING UNIT HAS BEEN POWERD FOR 24 HOURS.

2. Discharge/Suction Valve Operation (Condensing unit)

Back Position: Normal operation, process and manometer port closed

Front Position: Liquid/suction line connection closed

Middle Position: All ports open for evacuation, charge and manometer reading

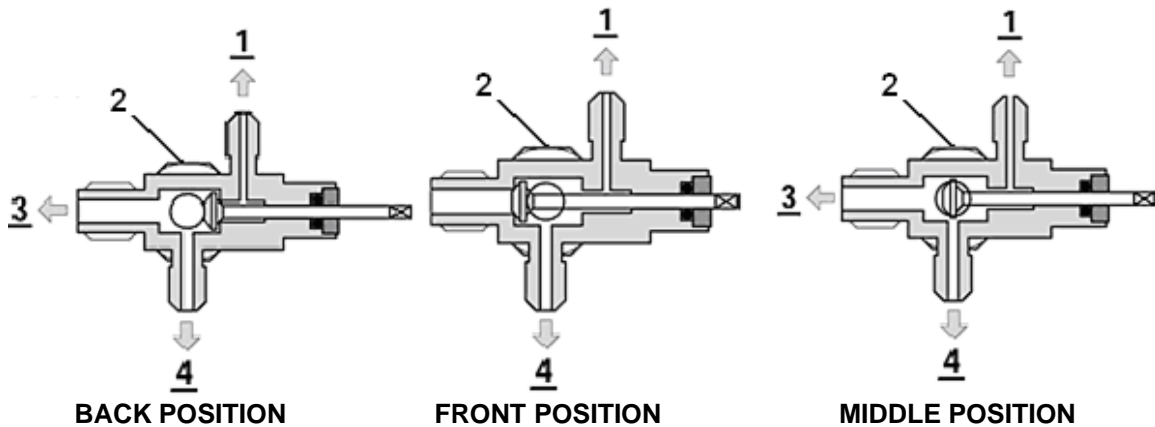

Fig. 6 ROTALOCK Valve Operation

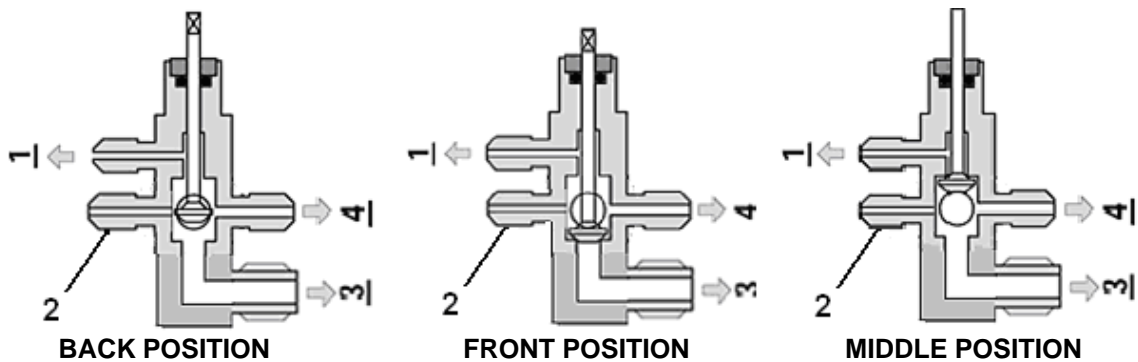

Fig. 7 Base Valve Operation

1 - Process & Manometer; 2 – Receiver Discharge or Compressor Suction
3 – Liquid Line or Suction Line; 4 - Pressure Control

3. Evaporator Unit

- The WM25-45SFCV evaporator units should be installed for corner mount with the air supply from the top and air return on the bottom.
- Supply air flow shall be unobstructed for at least 12" for free installation or 2" for deflector installation and return air shall be unobstructed for 6".
- Grille can be used to cover the supply and return, and also 2-3 ft long duct can be added.
- There is a gravity drain line and the unit shall be installed level or with a slight angle toward the drain connection. If rise-up is needed, a condensation pump must be used.

4. Air Sensor and Temperature Controller

- The air sensor can be located in the wine room 5 ft above the floor or the return air area, but not the supply air area or air dead area.
- If the temperature controller is mounted outside the wine room but the air sensor is located inside the wine room, use 18 gauge wires to extend the air sensor if needed.

5. Piping, Evacuating, Charging and Starting

CAUTION:

- **ALWAYS USE THE SUPERHEAT AND SUBCOOLING, PRESSURE READINGS TO CHARGE REFRIGERANT PROPERLY, THE LISTED CHARGES ARE FOR REFERENCE ONLY.**
- **CHARGE 15% MORE REFRIGERANT IN THE SUMMER IF THE UNIT IS EQUIPPED WITH A LOW AMBIENT CONDITION KIT..**

NOTES:

- **THE LINE CONNECTION SIZES OF LIQUID FILTER & INDICATOR, THE VALVE CONNECTION SIZES OF CONDENSING UNIT AND THE LINE CONNECTION SIZES OF EVAPORATOR UNIT ARE NOT NECESSARY THE SAME AS THE ABOVE LISTED LINE SIZES.**
- **IF THE CONDENSING UNIT IS INSTALLED ABOVE THE EVAPORATOR UNIT, USE THE SUCTION LINE ONE LISTED SIZE SMALLER. EXPANSION AND SOLENOID VALVES ARE INSTALLED ON LIQUID LINE.**

- 1) The installation order starts from condensing unit (including receiver and discharge valve), liquid line filter-drier, moisture-liquid indicator/sight glass, liquid line, to evaporator unit (including liquid line connection, solenoid valve, expansion valve, and suction line connection), returning to insulated suction line, suction valve and then back to condensing unit.
- 2) Use inverted siphons to prevent liquid from flooding back to the compressor and aid oil returning to the compressor.
- 3) Both discharge and suction valves must be in the middle positions during evacuating and charging.
- 4) Charge the system after pipe brazing, leak testing and evacuating. Liquid must always be charged into the high side.
- 5) It may use fan speed control to adjust the air flow to achieve the specified CFM. Turn control knob clockwise to the lowest speed position, locate and adjust the minimum speed setting (on the side or front) with screw driver. Rotate the setting clockwise to decrease minimum speed or counter-clockwise to increase minimum speed). The minimum speed should be adjusted until it supplies the required CFM. The fan will run from this preset minimum speed to full speed with the control knob at lowest and highest speed position.

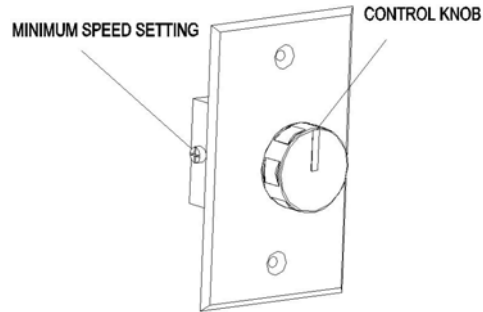

Fig. 8 Fan Speed Control

- 6) The subcooling at the condensing unit shall be around 10° F. The charge may be complete when there are no more bubbles forming in the liquid indicator.
- 7) Head pressure range: 125 ~ 150 psig at 70 ~ 90 °F condensing unit ambient temperature.
- 8) The evaporator's constant pressure expansion valve is set around 30 ~ 35 psig (35 ~ 40°F) at factory. This pressure setting gives a dew point to maintain the humidity for storing wine.
- 9) The temperature split between return air and supply air shall be 8 ~ 10°F at 55°F wine room temperature.
- 10) Again, must verify if the superheat at the evaporator unit is around 9 ~ 18°F at 50 ~ 65 °F wine room temperature with a normal condensing unit ambient temperature.
- 11) If the superheat is high, check the subcooling first to know if the refrigerant charge is sufficient. If the charge is not sufficient, add more refrigerant. If the charge is good, then increase the evaporator suction pressure by turning the hex nut (5/16") clockwise.
- 12) If the superheat is low, then decrease the evaporator suction pressure by turning the hex nut (5/16") counter-clockwise.
- 13) Both discharge and suction valves must be in the back positions before disconnecting evacuating and pressure gauges.

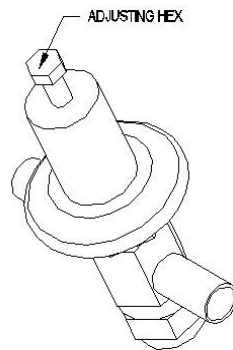

Fig. 9 Expansion Valve

The line sizes and refrigerant charges are listed as follows.

MODEL	REFRIGERATION LINES	LIQUID LINE	SUCTION LINE	DRAIN LINE	CHARGE
VINO-2500SSV	<=50 FT	1/4" OD	3/8" OD	1/2" OD	R134a/19 OZ
VINO-4500SSV	<= 50 FT	1/4" OD	1/2" OD	1/2" OD	R134a/26 OZ
VINO-6500SSV	<= 50 FT	1/4" OD	1/2" OD	1/2" OD	R134a/32 OZ

6. Use of the adjustable pressure control (if applicable for pump-down)

Suction pressure setting: Cut out=5 psig; Cut in=25 psig; Differential=20 psig
 Head pressure setting: Cut out=230 psig; Cut in=150 psig; Differential=80 psig
 It may need to adjust the setting in the field to get the right cycle time.

A. P70 Single/Dual Control

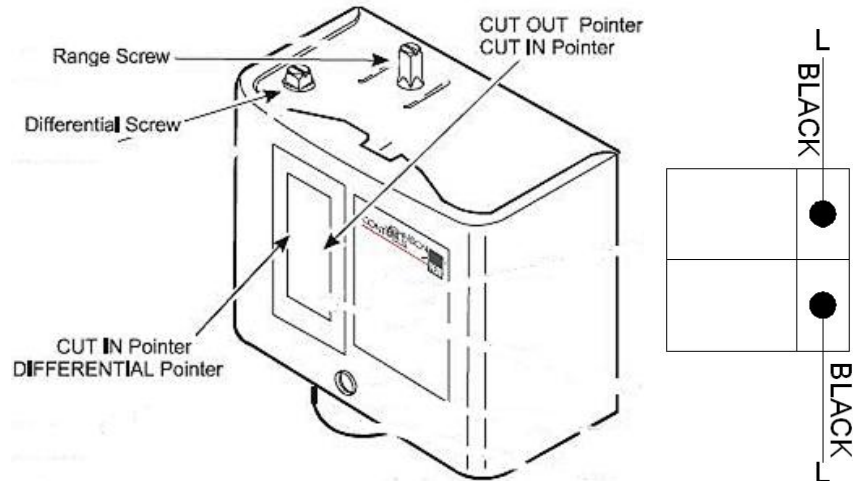

Fig. 10 Adjustable Pressure Control

B. PS2 Dual Control

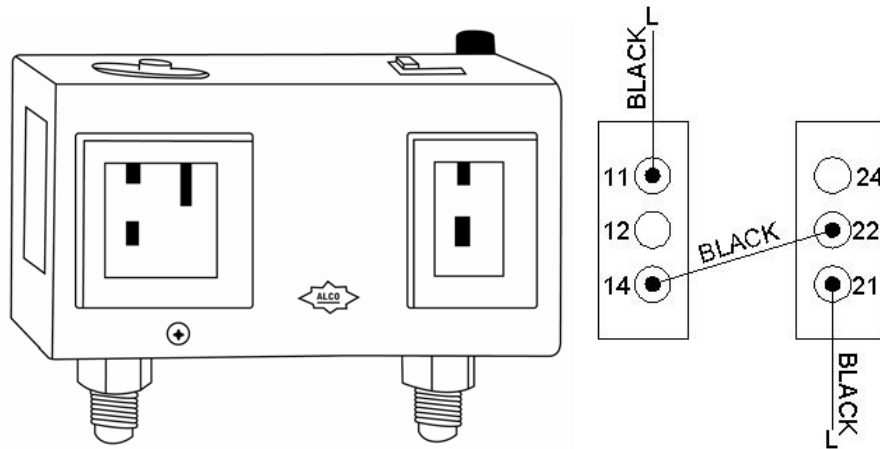

Fig. 11 Adjustable Pressure Control

7. Use of the encapsulated pressure control (if applicable)

Fixed suction pressure setting: Cut in = 32 psig; Cut out = 10 psig

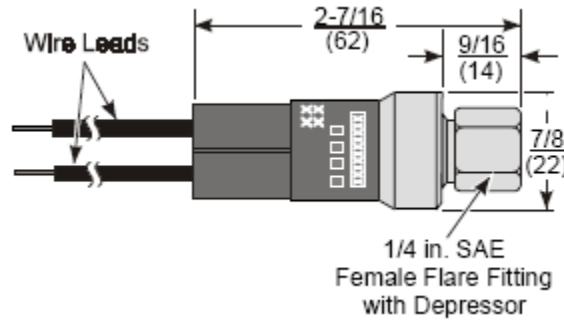

Fig. 12 Fixed Pressure Control

8. Use of the condenser fan control (if applicable for low ambient kit)

Head pressure setting: Cut in=170 psig; Cut out=120 psig; Differential=50 psig

It closes on rise of pressure. It may need to adjust the setting in the field to avoid fan short cycle.

9. Use of the crankcase heater (if applicable for low ambient kit)

The crankcase heater is installed around the lower part of the compressor and shall be turned on all the time. The heater is self-regulated.

10. Pressure, Superheat and Subcooling Readings

CAUTION:
THE VALVES MUST BE IN THE MIDDLE POSITIONS TO READ PROPERLY.

Complaint	Possible Causes
a. High suction pressure and low head pressure Zero superheat and zero subcooling	a. Compressor may be bad
b. High suction pressure and low head pressure Low superheat and low subcooling	b. Expansion valve opened, too much oil
c. High suction pressure and high head pressure Low superheat and high subcooling	c. Overcharge
d. High to normal suction pressure and high head pressure Low subcooling	d. Non-condensable gas
e. High suction pressure and high head pressure Low superheat and low subcooling	e. Air restricted, dirty condenser, bad condenser fans
f. High suction pressure and high head pressure High superheat	f. High room temperature, high evaporator load
g. Low suction pressure and low head pressure High superheat and low subcooling	g. Undercharge
h. Low suction pressure and low to normal head pressure High superheat and high subcooling	h. Liquid line restricted after receiver, solenoid valve restricted

i. Low suction pressure and low head pressure Normal to high superheat and low subcooling	i. Suction line restricted
j. Low suction pressure and low head pressure Low superheat and low subcooling	j. Air restricted at evaporator, evaporator iced
k. Low suction pressure and low to normal head pressure High superheat and normal to high subcooling	k. Evaporator restricted
l. Low suction pressure and normal head pressure High superheat and normal subcooling	l. Expansion valve restricted
m. Low suction pressure and high head pressure High superheat and high subcooling	m. Both evaporator and condenser restricted; liquid and suction lines connected wrong
n. Low suction pressure and high head pressure High superheat and high subcooling	n. Liquid line restricted before receiver
o. low to normal suction pressure and high head pressure Normal to high superheat and high subcooling	o. Condenser restricted

11. Condensing Unit Troubleshooting

Unit not running	
a. Incorrect power supply	a. Check for proper voltage
b. Incorrect or loose wirings	b. Check all wirings and connections
c. Failed components	c. Check start relay, start capacitor, overload protector, compressor.
d. Liquid refrigerant in the compressor	d. Call service for OEM information
e. Low pressure switch shutting down the system	e. Check for system restriction or low refrigerant

Electrical Wiring

CAUTION:

- USE MINIMUM 14 GAUGE WIRES FOR POWER LINES.
- IF EQUIPPED WITH LOW AMBIENT CONDITION KIT, USE LOW AMBIENT TEMPERATURE WIRING DIAGRAMS. TURN OFF THE COMPRESSOR BEFORE POWER THE CONDENSING UNIT. ONLY TURN ON THE COMPRESSOR AFTER THE CONDENSING UNIT HAS BEEN POWERED FOR 24 HOURS.

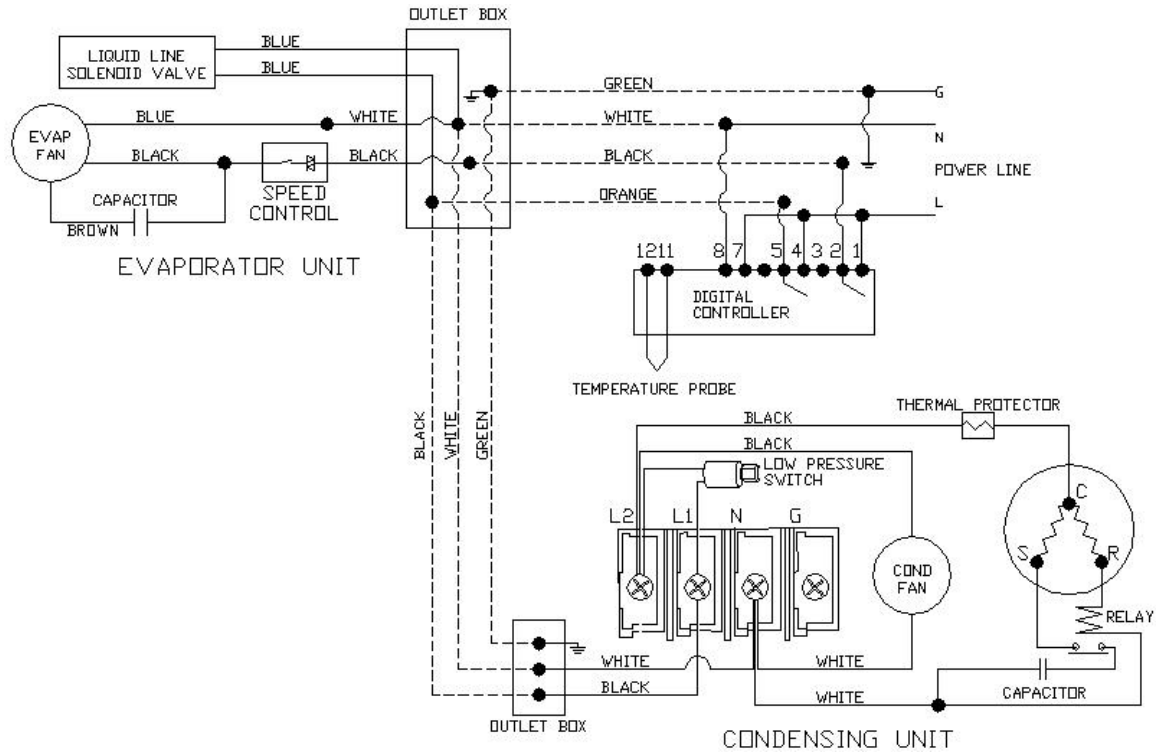

Fig. 13 VINO2500-4500SSV Wiring Diagram

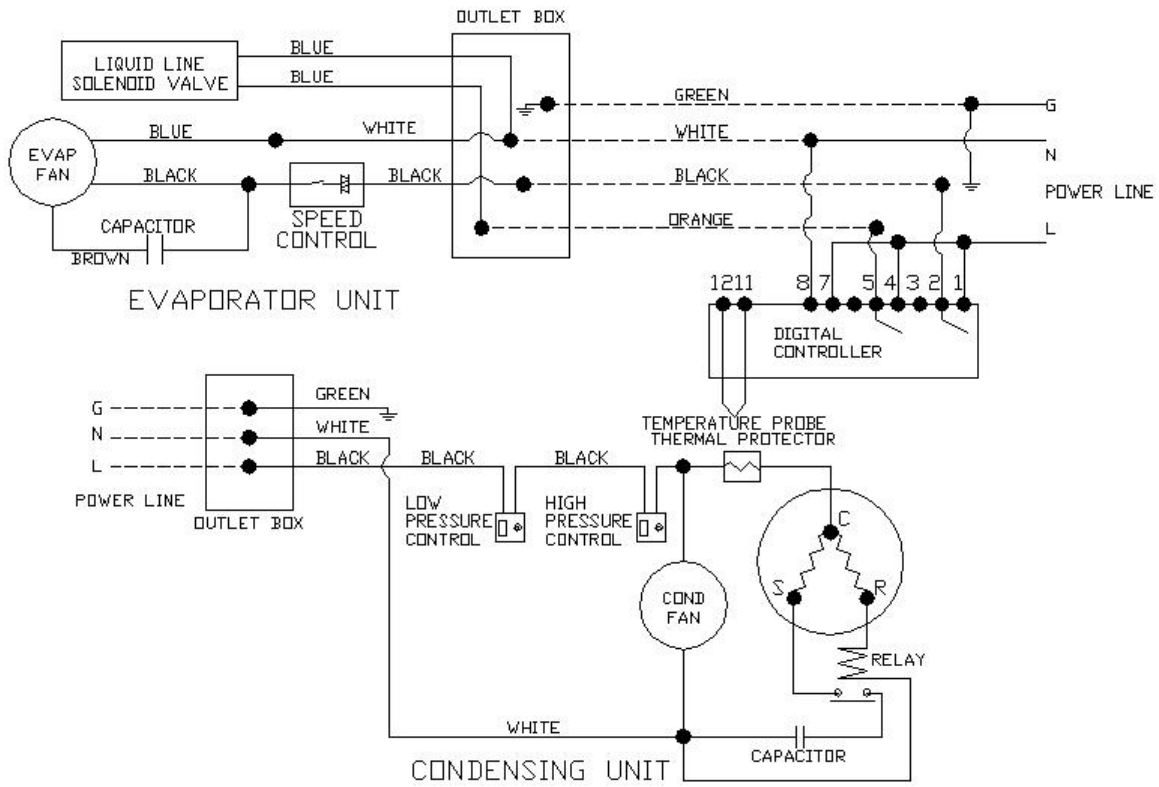
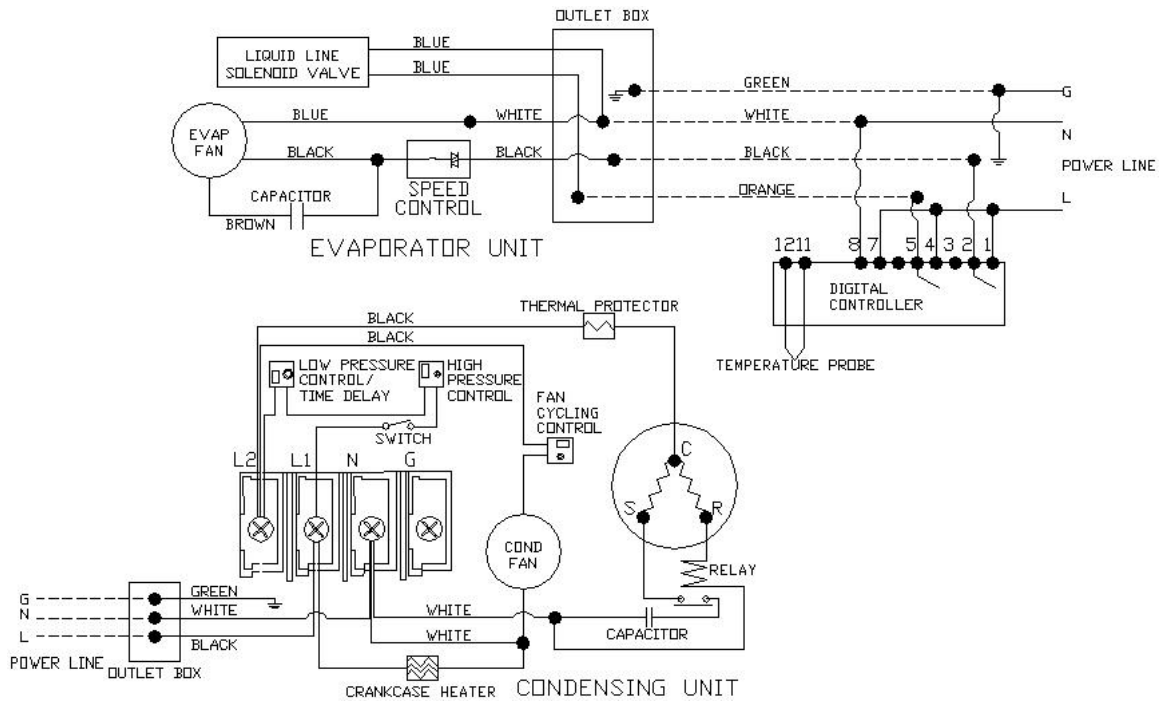

Fig. 14 VINO6500SSV Electrical Wiring Diagram



**Fig. 15 Low Ambient Temperature
VINO2500-4500SSV Wiring Diagram**

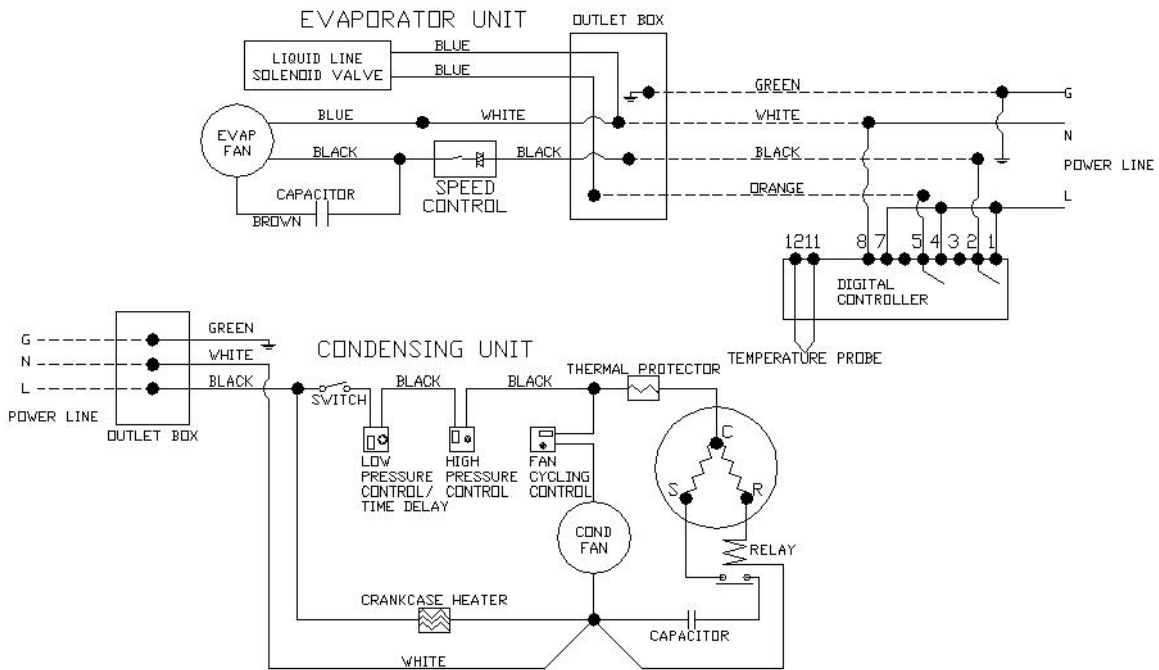

Fig. 16 Low Ambient Temperature VINO6500SSV Electrical Wiring Diagram

Temperature Control & Humidity Adjustment

1. Temperature Setting

- Set the temperature at 55 °F for the optimum aging of wine
- On initial start-up, the time required to reach the desired temperature will vary, depending on the quantity of bottles, temperature setting and surrounding temperature.
- Allow 24 hours to stabilize the temperature for each new temperature setting operation

1. Use of the controller

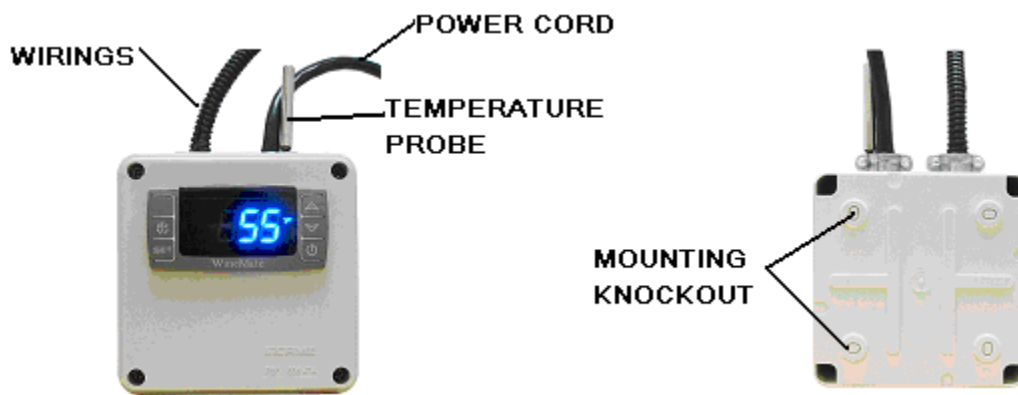

Fig. 17 Digital Controller (4.25”L X 3.75D X 4.25”H)

1) Keys

SET: To display target set point; in programming mode it selects a parameter or confirm an operation.

❄️(DEF): To start a manual defrost.

▲(UP): To see the maximum stored temperature; in programming mode it browses the parameter codes or increases the displayed value.

▼(DOWN): To see the minimum stored temperature; in programming mode it browses the parameter codes or decreases the displayed value.

⏻: To turn on/off the power to the unit.

▲+ ▼: To lock/unlock the keypad.







SET+ ▼: To enter in the programming mode.

SET+ ▲: To return to the temperature display.

2) Display

During normal operating conditions, the display shows the value measured by the air regulation probe. In case of active alarm, the temperature flashes alternately to the code alarm.

2.1 LED Functions

LED	MODE	FUNCTION
	ON	Compressor enabled
	Flashing	Anti-short cycle enabled
	ON	Defrost cycle enabled
	ON	Fan enabled
	Flashing	Fan delay after defrost enabled
	ON	Alarm occurring
°C/°F	ON	Temperature measuring unit
°C/°F	Flashing	Programming mode

3) Alarm Signals

3.1 Code Description

MESSAGE	CAUSE	FUNCTION
P1	Temperature probe faulty	Compressor switching to Con and CoF
HA	High temperature alarm	Outputs unchanged
LA	Low temperature alarm	Outputs unchanged
CA	External alarm	All outputs off

3.2 Alarm Recovery



Probe alarms P1”, start a few seconds after the fault in the related probe; they automatically stop a few seconds after the probe restarts normal operation. Check connections before replacing the probe. Temperature alarms “HA”, “LA” automatically stops as soon as the temperature returns to normal value. Alarm “CA” (with i1F=PAL) recovers only by switching off and on the instrument.

4) Temperature Set-Point







4.1 How to see the set-point

1. Press and immediately release the **SET** key, the display will show the set-point value.
2. Press again and immediately release the **SET** key or wait for 5 seconds to display the probe value again.

4.2 How to change the set-point

1. Press the **SET** key for more than 3 seconds until the “°C” or “°F” LED starts blinking and the set-point will be displayed.
2. To change the set value, press the up/down keys / within 10 sec.
3. To store the new set-point value, press the **SET** key again or wait 10 sec.

5) Parameter Programming

1. Press the **SET** +  keys for 3 sec until the “°C” or “°F” LED starts blinking, then release the keys.
2. Press again the **SET** +  keys for more than 7sec until the **Pr2** label will be displayed, then release the keys. The first parameter **Hy** will be displayed.
3. Press up/down keys / to select the required parameter within 10 sec.
4. Press the “**SET**” key to display its value.
5. Use up/down keys / to change its value within 10 sec.
6. Press “**SET**” to store the new value.
7. **To exit:** Press **SET** +  or wait 15sec without pressing a key.

PARAMETER	DESCRIPTION	VALUE
Set	set-point (°)	55
Hy	temperature regulation differential (°)	4
AC	anti-short cycle delay (min)	10
Con	compress on with probe faulty (min)	15
CoF	compress off with probe faulty (min)	30
CF	temperature unit (°F/°C)	F: Fahrenheit
rES	display resolution	in: integer
dLy	temperature display delay (min)	1
ot	probe calibration (°)	0
US	maximum set-point (°)	65
LS	minimum set-point (°)	50
idF	defrost cycle interval time (hour)	24
MdF	defrost cycle endurance time (min)	30
ALC	temperature alarm type	rE: relative to set-point
ALU	high temperature alarm (°)	10
ALL	low temperature alarm (°)	10
AFH	alarm recovery differential (°)	5
ALd	temperature alarm delay (min)	120
FnC	fan operating mode	C-n: on with compressor & off during defrost
Fon	fan on with compressor (min)	0
FoF	fan off with compressor (min)	15



Note:

- The parameter **Fon** is used to adjust the humidity in the wine cabinet. The higher **Fon** is, the higher relative humidity will be.
- The parameter **FnC = C-y** (on with compressor and on during defrost) with **idF = 8** and **MdF = 15** can be used to defrost more efficiently in case there is much frost.
- The unit turns on at set-point plus regulation differential **Hy** after anti-short cycle **AC** has elapsed and turns off at set-point.

7) Manual Defrost

Press the DEF key for more than 2 seconds and a manual defrost will start.

Care Guide

 WARNING	
	ELECTRIC SHOCK HAZARD Disconnect the electrical power before servicing any components. Failure to do so can result in death or electrical shock.

In general, always unplug system or disconnect power while doing care.

1. Coil Cleaning

- Clean the condenser coil regularly. Coil may need to be cleaned at least every 6 months.
- Unplug the system or disconnect power.
- Use a vacuum cleaner with an extended attachment to clean the coil when it is dusty or dirty.
- Plug cooling system or reconnect power.

2. Moisture Removing

- Remove the extra condensate if it is accumulated in the wine cellar at high ambient temperature and humidity.

User's Troubleshooting

This Troubleshooting Chart is not prepared to replace the training required for a professional refrigeration service person, not is it comprehensive

Complaint	Possible Causes	Response
1. Unit not running	<ul style="list-style-type: none"> a. No power b. Power cord unplugged c. Setting higher than ambient temperature d. Defrost light blinking e. Compressor light blinking f. Incorrect or loose wirings. g. Low voltage. 	<ul style="list-style-type: none"> a. Check power at receptacle & fuses b. Check for power cord plug c. Lower temperature setting d. Unit is under defrost mode e. Unit waits for anti-short cycle delay f. Check all wirings and connections g. Contact an authorized electrician
2. Displaying Temperature fluctuating	<ul style="list-style-type: none"> a. Air sensor 	<p>When using an air sensor, the wine bottle temperature is mainly controlled by the average air temperature. If the set-point is 55°F with a differential 4 °F, the cooling unit turns on at 59°F of air temperature and turns off at 55°F of air temperature. The average air temperature is 57°F, and then the wine temperature is around 57+/-0.5°F. The air is light enough to change so quickly that it maintains relatively constant average temperature that would prevent wine bottle temperature from varying.</p>
3. Temperature high, but displaying temperature low, unit stopping and starting with short running time	<ul style="list-style-type: none"> a. air sensor contacting the evaporator b. Short circuit of air flow between supply and return air c. Setting too high d. Failed temperature controller and air sensor 	<ul style="list-style-type: none"> a. Move the air sensor away from the evaporator b. Deflect the supply air down c. Lower setting d. Call service for diagnosis
4. Temperature high, compressor stopping and starting but short running time	<ul style="list-style-type: none"> a. Incorrect voltage b. Failed components c. Improper condenser airflow d. Dirty condenser e. Overcharge of refrigerant f. Discharge or suction pressure too high 	<ul style="list-style-type: none"> a. Check for voltage b. Check compressor windings, start relay and overload protector. c. Check for condenser fan d. Clean condenser e. Call service for removing refrigerant f. Call service for OEM information
5. Not cooling or temperature too high and	<ul style="list-style-type: none"> a. Improper room insulation & seal b. Room too large c. Ambient temperature too high d. Exhaust restricted 	<ul style="list-style-type: none"> a. Check for insulation, gasket and door opening b. Check for excessive size c. Check for installation location d. Leave minimum 3 ft clearance for

<p>running continually</p>	<ul style="list-style-type: none"> e. Malfunctioning fans f. Improper evaporator or condenser airflow g. Dirty Condenser h. Iced evaporator i. Sealed system problem j. Undercharge or overcharge 	<p>the exhaust side and leave minimum 1 foot clearance for the fresh air intake side</p> <ul style="list-style-type: none"> e. Check for both evaporator and condenser fans f. Check for air restrictions g. Clean condenser h. Defrost and reset temperature i. Call service for checking loss of refrigerant or restrictions j. Call service to add or remove refrigerant
<p>6.Unit running too long</p>	<ul style="list-style-type: none"> a. Improper room insulation & seal b. Exhaust restricted c. Room too large d. Ambient temperature extremely high e. Dirty Condenser 	<ul style="list-style-type: none"> a. Check for insulation, gasket and door opening b. Leave minimum 3 ft clearance for the exhaust side and leave minimum 1 foot clearance for the fresh air intake side c. Check for excessive size d. Check for installation location or increase setting e. Clean condenser
<p>7.Evaporator freezing up</p>	<ul style="list-style-type: none"> a. Evaporator air flow restriction b. Unit not stopping due to air leak, high ambient temperature or low setting c. Low ambient temperature d. Bad thermostat or sensor e. Refrigerant low or leak f. Expansion valve blockage 	<ul style="list-style-type: none"> a. Check for fans, CFM b. Check for seal, door opening, ambient temperature and setting c. Defrost the unit d. Check for thermostat and sensor e. Check for sealed system leakage f. Check for low side pressure
<p>8.Water leak</p>	<ul style="list-style-type: none"> a. Unit not level b. Drain line restricted c. Drip tray leak d. Very high humidity e. Wine room air leak 	<ul style="list-style-type: none"> a. Check for installation b. Check drain line c. Check for if water leak but no overflow d. Use dehumidifier e. Check for air leak and if condensation on the cooling unit
<p>9.Circuit tripping</p>	<ul style="list-style-type: none"> a. Incorrect fuse or breaker b. Incorrect wirings c. Overcharge of refrigerant d. Condenser air restriction e. Failed components 	<ul style="list-style-type: none"> a. Check for proper fuse or breaker b. Check for wirings and connections c. Call service for removing refrigerant d. Check condenser fan e. Call service

10.Noisy operation	a. Mounting area not firm b. Loose parts c. Compressor overloaded due to high ambient temperatures or airflow restriction d. Malfunctioning components	a. Add support to improve installation b. Check fans, cabinet washers, tubing contact and loose screws. c. Check for airflow blockage d. Call service for checking Internal loose, inadequate lubrication and incorrect wirings
---------------------------	---	--

Customer Support

If you still have problems, please contact us at:

Vinotemp International
17631 South Susana Road
Rancho Dominguez, CA 90221
Tel: (310) 886-3332
Fax: (310) 886-3310
Email: info@vinotemp.com

Warranty

Thank you for choosing a Vinotemp cooling unit.

Please enter the complete model and serial numbers in the space provided:

Model _____
Serial No. _____

Attach your purchase receipt to this owner's manual.

1. Limited Warranty

VINOTEMP warrants its products, parts only, to be free from defects due to workmanship or materials under normal use and service for twelve months after the initial sale. If the product is defective due to workmanship or materials, is removed within twelve months of the initial sale and is returned to VINOTEMP, in the original shipping carton, shipping prepaid, VINOTEMP will at its option, repair or replace the product free of charge.

This warranty constitutes the entire warranty of the VINOTEMP with respect to its products and is in lieu of all other warranties, express or implied, including any of fitness for a particular purpose. In no event shall VINOTEMP be responsible for any consequential damages what is so ever. Any modification of VINOTEMP products shall void this warranty.

Service under Warranty

This service is provided to customers within the continental UNITED STATES only. VINOTEMP cooling units are warranted to produce the stated number of BTU/H. While every effort has been made to provide accurate guidelines, VINOTEMP can not warranty its units to cool a particular enclosure.

In case of failure, VINOTEMP cooling units must be repaired by the factory or its authorized agent. Repairs or modifications made by anyone else will void the warranty.

Shall a VINOTEMP cooling unit fail, contact the dealer for instructions, do not return the unit to the factory without authorization from VINOTEMP. If the unit requires repair, re-pack it in the original shipping carton and return it to the factory, shipping prepaid. VINOTEMP will not accept COD shipments. If the unit is determined to be faulty and is within the twelve month warranty period

VINOTEMP will, at its discretion, repair or replace the unit and return it free of charge to the original retail customer. If the unit is found to be in good working order, or beyond the initial twelve month period, it will be returned freight collect.

2. Limitation of Implied Warranty

VINOTEMP'S SOLE LIABILITY FOR ANY DEFECTIVE PRODUCT IS LIMITED TO, AT OUR OPTION, REPAIRING OR REPLACING OF UNIT.

**VINOTEMP SHALL NOT BE LIABLE FOR:
DAMAGE TO OTHER PROPERTY CAUSED BY ANY DEFECTS IN THE UNIT,
DAMAGES BASED UPON INCONVENIENCE, LOSS OF USE OF THE UNIT,
LOSS OF TIME OR COMMERCIAL LOSS, ANY OUTER DAMAGES,
WHETHER INCIDENTAL, CONSEQUENTIAL OR OTHERWISE.**

**THIS WARRANTY IS EXCLUSIBE AND IS IN LIEU OF ALL OTHER
WARRANTIES, EXPRESSED OR INPLIED, INCLUDING BUT NOT LIMITED
TO, IMPLIED WARRANTIES OF MERCHANTABILITY OR FITNESS FOR A
PARTICULAR PURPOSE.**

While great effort has been made to provide accurate guidelines VINOTEMP cannot warrant its units to properly cool a particular enclosure. Customers are cautioned that enclosure construction, unit location and many other factors can affect the operation and performance of the unit. There for suitability of the unit for a specific enclosure or application must be determined by the customer and cannot be warranted by VINOTEMP.