

VINO1500-2500SSW Installer's Instruction

WARNING



Always check wiring harness connections before initiating any test procedures.

Disconnect electric power from the appliance before performing any maintenance or repairs.

Voltage checks should be made by inserting meter probes beside the wires in the connector blocks with the electric power source on and the connector block plugged in.

Resistance checks should be made on components with the electric power off and the connector block disconnected.

Federal law requires that WINE-MATE split cooling systems be installed by an EPA certified refrigeration technician.

WINE-MATE split system is shipped as components and is ready for use only after a certified refrigeration technician has properly installed, evacuated, charged and tested the system. Proper installation is critical. Vinotemp can only warrant the quality of the components. The installation and proper operation of the system must be warranted by the installer. Installation of the system must be done in accordance with all state and local building and electrical codes.

The condensing unit and evaporator unit are connected by a liquid line and an insulated suction line that are supplied by the installer. These lines must be properly sized for the distance between the two units. After the units and the lines are installed, the system must be pressure tested. If no leaks are found, evacuate and charge system. Refrigerant amount will vary depending on the length of line set.

1. Condensing Unit

- Place the condensing units WM150SCU and 250SCU in a properly ventilated location. If it is not, heat exhausted by the condensing unit will build up and the cooling system will not operate properly.
- Condensing unit shall be elevated to avoid possible flooding and shaded from direct sun. It shall not be exposed to temperatures higher than 110 °F or lower than 50 °F (optional low ambient kit available).
- Leave minimum 5 feet clearance for the exhaust side and leave minimum 1 foot clearance for the fresh air intake side.



CAUTION:

DO NOT SWITCH ON THE COMPRESSOR IF THE CONDENSING UNIT IS EQUIPPED WITH A LOW AMBIENT CONDITION KIT UNTIL THE UNIT HAS BEEN PLUGGED IN FOR 24 HOURS.

2. Valve Operation (Condensing unit)

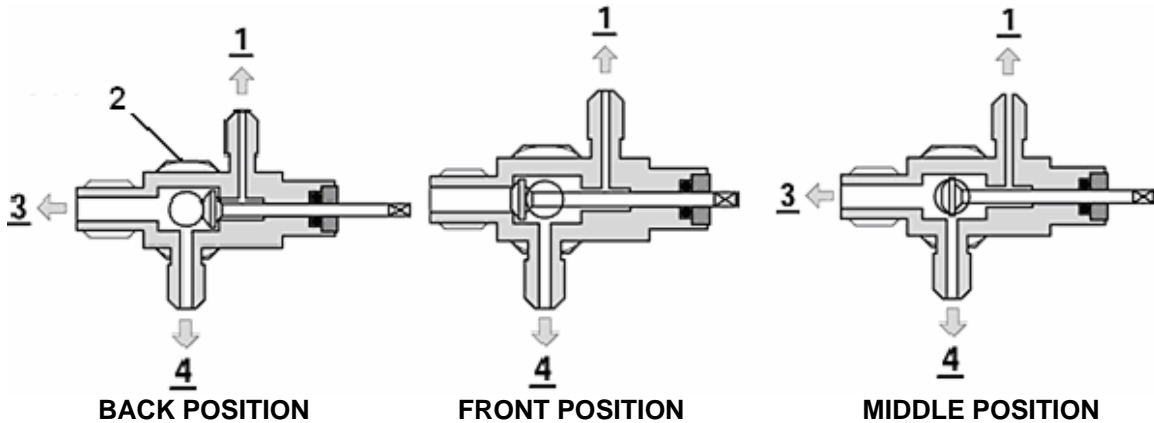

Fig. 1 ROTALOCK Valve Operation

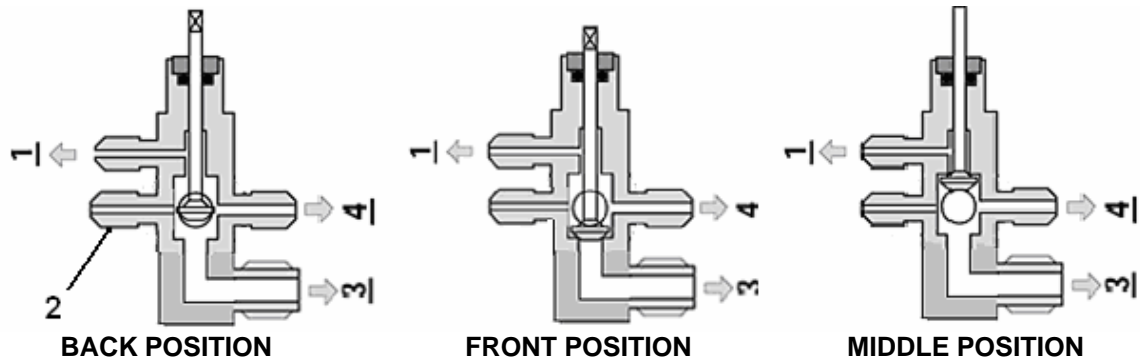

Fig. 2 Base Valve Operation

1 - Process & Manometer; 2 - Receiver/Compressor Suction

3 - Liquid/Suction Line; 4 - Pressure Control

Back Position: Process and manometer port closed for normal operation

Front Position: Connection to liquid or suction line closed

Middle Position: All ports open for evacuation, charge and manometer reading

3. Evaporator Unit

- The WM15-25SFCW evaporator units shall be installed for wall mount with the air supply on the top and air return on the bottom.
- Supply and return air flow from the evaporator unit shall be unobstructed for at least 1 foot.

- There is a gravity drain line and the unit shall be installed level or with a slight angle toward the drain connection. If rise-up is needed, a condensation pump must be used.

4. Air Sensor

- The air sensor can be located in the wine room 5 feet above the floor or the return air area, but not the supply air area or air dead area.
- If the temperature controller is mounted outside the wine room but the air sensor is located inside the wine room, use 18 gauge wires to extend the air sensor if needed.

5. Refrigeration Piping, Evacuating, Charging and Starting

CAUTION:

- **ALWAYS USE THE SUPERHEAT AND SUBCOOLING, PRESSURE READINGS TO CHARGE REFRIGERANT PROPERLY, THE LISTED CHARGES ARE FOR REFERENCE ONLY.**
- **CHARGE 15% MORE REFRIGERANT IN THE SUMMER IF THE UNIT IS EQUIPPED WITH A LOW AMBIENT CONDITION KIT.**

- The installation order starts from condensing unit (including the receiver, discharge valve), liquid line filter-drier, moisture-liquid indicator/sight glass, liquid line, to evaporator unit (including liquid line connection, solenoid valve, expansion valve, and suction line connection), returning to insulated suction line, suction valve and then condensing unit.
- Use inverted siphons to prevent liquid from flooding back to the compressor and aid oil returning to the compressor.
- Charge the system after pipe brazing, leak testing and evacuating.
- The subcooling at the condensing unit shall be around 10°F. The charge may be complete when there are no more bubbles forming in the sight glass.
- The evaporator's constant pressure expansion valve is set around 35-40°F at factory. This pressure setting gives a dew point to maintain the humidity for storing wine.
- The superheat at the evaporator unit shall be around 9-18°F under low - high load at 75°F ambient temperature.
- If the superheat is high, check the subcooling first to know if the refrigerant charge is sufficient. If the charge is not sufficient, add more refrigerant. If the charge is good, then increase the evaporator suction pressure by turning the hex nut (5/16") clockwise.
- If the superheat is low, then decrease the evaporator suction pressure by turning the hex nut (5/16") counter-clockwise.

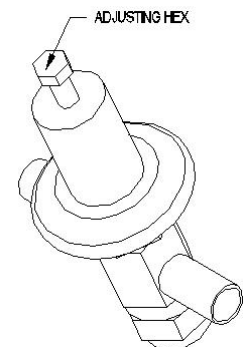

- It may use fan speed control to adjust the system refrigeration performance to achieve 8-10°F differential between return air and supply air. **In order to control fan speed properly, a minimum speed adjustment is required. Turn main control knob to lowest speed position, locate the setting (on the side or front) and adjust minimum speed setting with screw driver (rotate clockwise to decrease minimum speed; counter-clockwise to increase minimum speed). The fan will run from this preset minimum speed to full speed.**
- Suction pressure: 30-35 psig
- Head pressure: 125-150 psig at 70 -90 °F ambient temperatures

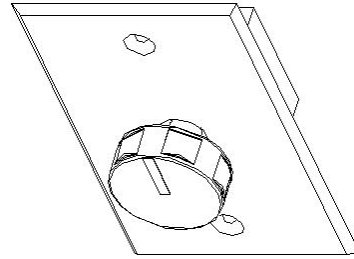

The line sizes and refrigerant charges are listed as follows.

MODEL	REFRIGERATION LINES	LIQUID LINE	SUCTION LINE	DRAIN LINE	CHARGE
VINO-1500SSW	<= 50 FT	1/4" OD	3/8" OD	1/2" OD	R134a/ 15 OZ
VINO-2500SSW	<= 50 FT	1/4" OD	3/8" OD	1/2" OD	R134a/ 19 OZ

NOTES:

- **THE VALVE CONNECTION SIZES OF CONDENSING UNIT AND THE LINE CONNECTION SIZES OF EVAPORATOR UNIT ARE NOT NECESSARY THE SAME AS THE ABOVE SPECIFIED LINE SIZES.**
- **IF THE CONDENSING UNIT IS INSTALLED ABOVE THE EVAPORATOR UNIT, USE THE SUCTION LINE ONE LISTED SIZE SMALLER.**
- **EXPANSION AND SOLENOID VALVES ARE INSTALLED ON LIQUID LINE.**

6. Pressure, Superheat and Subcooling Readings

CAUTION:

THE VALVES MUST BE IN THE MIDDLE POSITIONS TO READ PROPERLY.

Complaint	Possible Causes
a. High suction pressure and low head pressure	a. Compressor may be bad
b. High suction pressure and low head pressure Low superheat and low subcooling	b. Expansion valve opened, too much oil
c. High suction pressure and high head pressure Low superheat and high subcooling	c. Overcharge
d. High to normal suction pressure and high head pressure Low subcooling	d. Non-condensable gas
e. High suction pressure and high head pressure Low subcooling	e. Air restricted, dirty condenser, bad condenser fans
f. High suction pressure and high head pressure High superheat	f. High room temperature, high evaporator load

g. Low suction pressure and low head pressure High superheat and low subcooling	g. Undercharge
h. Low suction pressure and low to normal head pressure High superheat and high subcooling	h. Liquid line restricted after receiver, solenoid valve restricted
i. Low suction pressure and low head pressure Low subcooling	i. Suction line restricted
j. Low suction pressure and low head pressure Low superheat and low subcooling	j. Air restricted at evaporator, evaporator iced
k. Low suction pressure and low to normal head pressure High superheat and normal to high subcooling	k. Evaporator restricted
l. Low suction pressure and normal head pressure High superheat and normal subcooling	l. Expansion valve restricted
m. Low suction pressure and high head pressure High superheat and high subcooling	m. Both evaporator and condenser restricted
n. Low suction pressure and high head pressure High superheat and high subcooling	n. Liquid line restricted before receiver
o. low to normal suction pressure and high head pressure High to normal superheat and high subcooling	o. Condenser restricted

7. Use of the adjustable pressure control (if applicable for pump-down)

Suction pressure setting: Cut out=5 psig; Cut in=25 psig; Differential=20 psig

Head pressure setting: Cut out=230 psig; Cut in=150 psig; Differential=80 psig

It may need to adjust the setting in the field to get the right cycle time.

A. Single Control

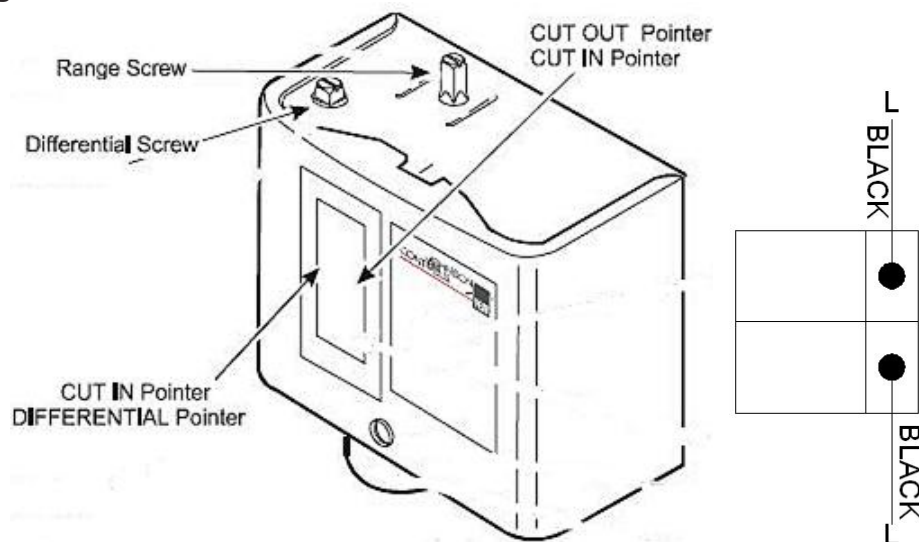

Fig. 3 Single Adjustable Pressure Control

B. Dual Control

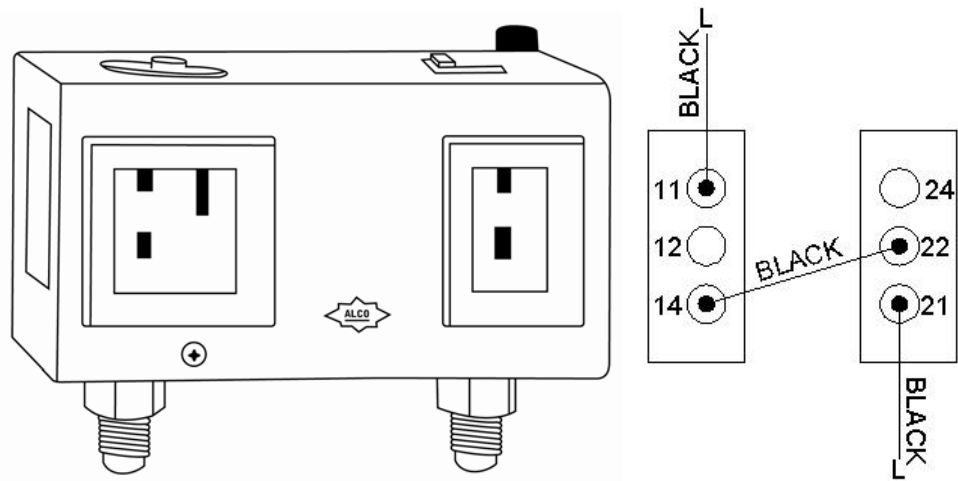
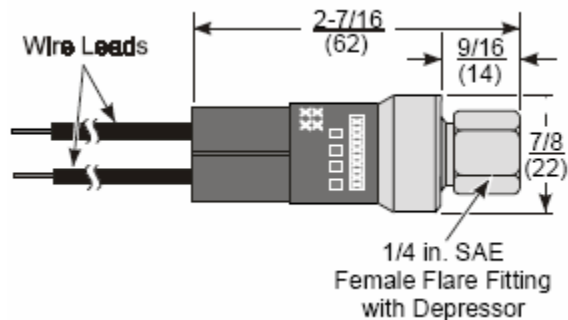

Fig. 4 Dual Adjustable Pressure Control

8. Use of the encapsulated pressure control (if applicable)

Fixed suction pressure setting: Cut in = 32 psig; Cut out = 10 psig



9. Use of the condenser fan control (if applicable for low ambient kit)

Head pressure setting: Cut in=170 psig; Cut out=120 psig; Differential=50 psig

It may need to adjust the setting in the field to prevent short fan cycle.

10. Use of the crankcase heater (if applicable for low ambient kit)

The crankcase heater is installed around the lower part of the compressor and shall be turned on all the time. The heater is self-regulated.

CAUTION:

TURN OFF THE COMPRESSOR SWITCH BEFORE POWER THE CONDENSING UNIT. ONLY TURN ON THE COMPRESSOR AFTER THE UNIT HAS BEEN POWERED FOR 24 HOURS.

11. Condensing Unit Troubleshooting

Unit not running	
a. Incorrect power supply	a. Check for proper voltage
b. Incorrect or loose wirings	b. Check all wirings and connections
c. Failed components	c. Check start relay, start capacitor, overload protector, compressor.
d. Liquid refrigerant in the compressor	d. Call service for OEM information
e. Low pressure switch shutting down the system	e. Check for system restriction or low refrigerant