

Vinotemp®

A PROUD HERITAGE OF EXPERIENCE & QUALITY

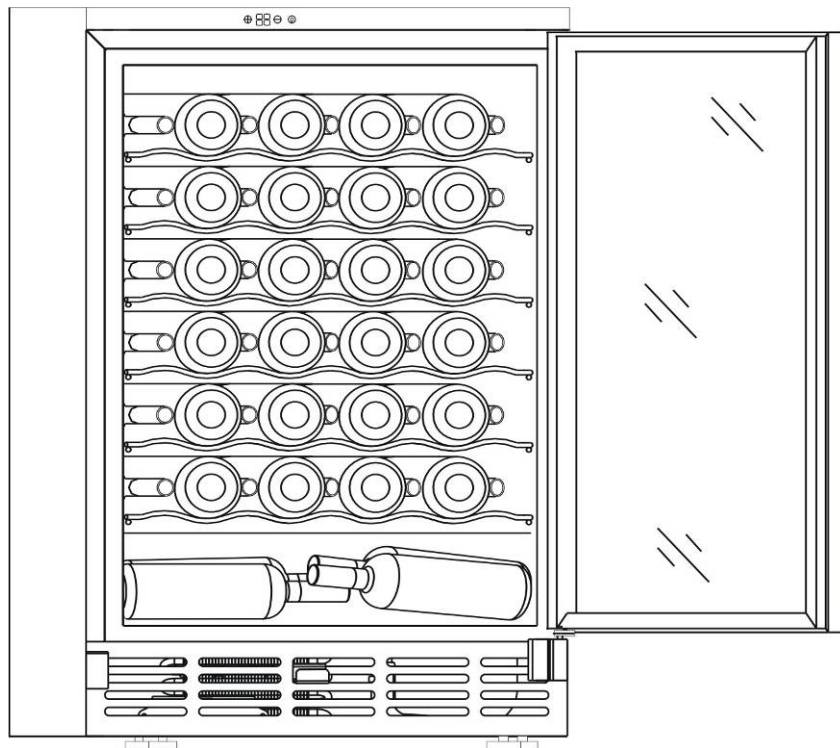

WINE CELLAR

VT-58 (58 BOTTLE)

OWNER'S MANUAL

Vinotemp®

WWW.VINOTEMP.COM

YOUR WINE CELLAR

This unit can be used for Storage and/or Service. The unit has a glass door and soft interior light that you can leave on to elegantly display your wine.

SERVING WINES

Storing wines at the proper temperature is important. To preserve them as long as possible, wine should be stored at approximately 55° Fahrenheit. However, the chart below suggests the optimal drinking temperature for the different styles of wine.

°C	°F	Wine Style
19	66	Armagnac, Brandy, Cognac
18	64.5	Full Bodied Red wines, Shiraz
17	62	Tawny Port
15	59	Medium Bodied Red Wines
14	57	Amontillado Sherry
13	55.5	Light Bodied Red Wines
12	53.5	Full Bodied White Wines
11	52	Medium Bodied White Wines
10	50	Rosé, Light Bodied White Wines
9	48	Vintage Sparkling
8	53.5	Fino Sherry
7	44.5	Non Vintage Sparkling

General Operating Instructions

Remove all external and internal packaging from your wine cellar. Be sure that all parts have been included before discarding any packaging materials. You may want to keep the box and packing materials for use at a later date.

Upon receipt and inspection of unit, the supply cord must be replaced if it is damaged. Contact our customer service at 1-800-777-8466 or info@vinotemp.com.

- Let the unit rest, UNPLUGGED for 24 hours once you have it placed in your home.
- Please fully read the instruction manual.
- Save these instructions.

**Please read and follow all safety rules
and operating instructions before using.**

Table of Contents

Parts And Specifications	6
Important Safety Instructions	7
Cord Instructions	8
Wine Cellar Installation	8
Temperature Control.....	9
Reversal Of Door Swing.....	10
Cleaning And Care.....	11
Moving Your Wine Cellar.....	11
Troubleshooting	12
Terms Of Sale And Warranty.....	13
Service & Important Notice.....	14

PARTS AND SPECIFICATIONS

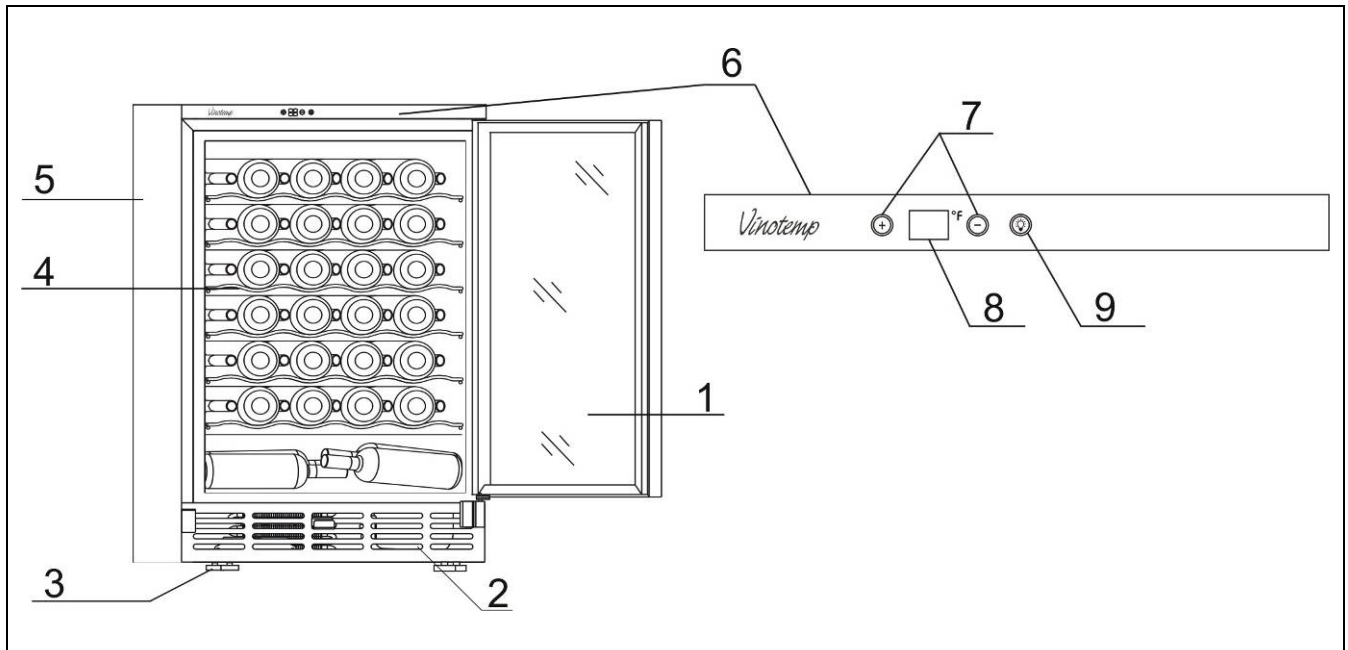

1. Double-Pane Window
2. Grill
3. Adjustable Leveling Legs
4. Shelf
5. Cabinet
6. PVC Control Panel
7. Temperature Adjustment Button
8. LED Temperature Indicator
9. Light Switch

Type	1 Temp.
Item Number	VT-58
Bottle Capacity	Approx. 58
Dimension (HxWxD) without handle	34.5"×24"×23"
Weight	105.8 Lbs
Power Consumption	2.5 kW.h/24h
Cooling System	R134a
Ambient Temp. Range	60 ~ 90°F
Temperature Range	45 ~ 65°F
Rated Voltage	115V
Rated Frequency	60Hz
Input Power	200W

IMPORTANT SAFETY INSTRUCTIONS

When using an electrical appliance, basic precautions should be followed to reduce the risk of fire, electric shock, and personal injury.

1. Use this appliance only as described in this manual. Other uses are not recommended and may cause fire, electric shock or injury.
2. This product is intended for household use.
3. To protect against electric shock, do not immerse unit, plug or cord in water or other liquids. Avoid locating the unit in moist areas.
4. Never allow children to operate, play with, or crawl inside the unit.
5. Unplug from the outlet when not in use, when moving from one location to another, or before cleaning.
6. To disconnect the appliance, grip the plug and pull it from the wall outlet. Never pull by the cord.
7. Do not operate the appliance in the presence of explosive and/or flammable fumes.
8. Do not place the appliance or any of its parts near an open flame, cooking or other heating appliance.
9. Do not operate the appliance with a damaged cord or plug. If the product malfunctions, or if it is dropped or damaged in any manner, do not use.
10. The use of attachments is not recommended and may be hazardous.
11. Do not operate if the housing is removed or damaged.
12. A loose fit plug may cause overheating and a distortion of the plug. Contact a qualified electrician to replace loose or worn outlet.
13. This appliance is designed to be built-in (fully recessed) or free standing.
14. The wine cellar is intended for use in a controlled ambient location such that the ambient temperature does not exceed 90°F (32°C).
15. Locate the unit away from direct sunlight and sources of heat (stove, heater, radiator, etc.). Direct sunlight may affect/alter the outside color of the appliance.

WARNING: To reduce the risk of fire, electric shock or personal injury, unplug or disconnect the appliance from the power supply before servicing.

WARNING: Risk of child entrapment. Before you throw away an old wine cellar, take off the door and leave the shelves in place so that children may not easily climb inside.

CORD INSTRUCTIONS

For your protection, this unit should be properly grounded. Unit is equipped with a 3-conductor cord set that has a molded 3-prong grounding-type plug, and should be used in combination with a properly connected grounding-type outlet as shown in figure A.

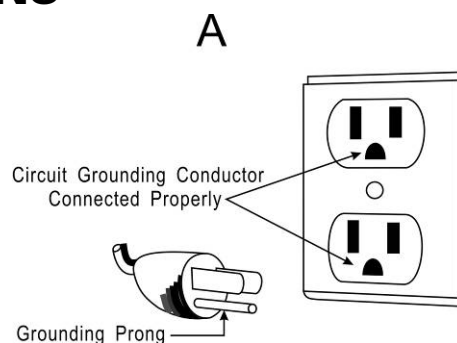

It is not recommended to use this wine cellar with an extension cord or power board. Please ensure that the appliance is plugged directly into the electrical outlet.

WINE CELLAR INSTALLATION

- Remove the exterior and interior packaging before use.
- Check to be sure you have all of the parts, including an accessory kit and 1 owner's manual.
- Place your wine cellar on a flat, dry surface that is strong enough to support the unit when fully loaded.
- This unit is designed to be built-in (fully recessed) or free standing.
- Do not place heavy objects on top of the unit.
- Unit is not designed for installation in a garage or basement.
- Do not place the unit in direct sunlight or near sources of heat. Extreme hot and cold ambient temperatures may cause the unit not to perform properly or increase electrical consumption.
- Do not place the unit next to a major appliance that emits large amounts of heat, such as a dishwasher, microwave, oven, etc.
- Do not plug unit into the same outlet as a refrigerator or microwave.
- Before connecting the appliance to the power source, let it stand upright for approximately 24 hours. This will reduce the possibility of a malfunction in the cooling system from handling during transportation.
- Clean the interior surface with lukewarm water using a soft cloth before first use.

OPERATING INSTRUCTIONS

1. Gently place/slide the racks in the wine cellar.
2. Determine the best temperature setting to use.
3. Place bottles inside the cooler.
4. Plug the power cord into a standard grounded electrical outlet.
5. Limit the frequency of opening the door to conserve energy and maintain proper storage temperature.
6. You can turn the interior light on and off by touching the button labeled with a light on the front control panel.
7. If unit is equipped with a lock, insert provided key and turn to operate lock. Make sure key is kept in a secure place when not in use.

Important: When using the wine cellar for the first time, allow at least 24 hours for the internal temperature to adjust properly. Make sure there are at least 3 to 5 bottles in the unit.

TEMPERATURE CONTROL

Important: In order to operate efficiently, this product should be in an environment with an ambient temperature of less than 90°F (32°C).

Temperature preset:

For your convenience, the wine cellar is programmed at storing temperature. The temperature pre-set by the manufacturer is 54°F (12°C).

Setting the temperature:

You can manually adjust the temperature. Simply press the “ - ” button on the control panel to decrease the temperature and the “ + ” button to increase the temperature by 1 degree inside the wine cellar. The temperature range for this unit is from 45°F (7°C) to 65°F (18°C).

When the cabinet temperature is too low, the LED will display “LL”. When the temperature is too high, it will display “HH”. The “ER” display shows when there has been a power disruption.

REVERSAL OF DOOR SWING

The door of the wine cellar could be opened either from the left or right side. The wine cellar is installed to open from the left side.

To reverse, please do as follows:

1. Disconnect the power, take out all the wines and lay the wine cellar back on the ground.
2. Remove the screw on the right downward hinge cover and remove the right downward hinge cover.
3. Remove the screw on the right downward hinge and remove the right downward hinge.
4. Remove the screw on the door support and remove the cover of door support.
5. Remove the fixing screw on the door support and remove the door support.
6. At this point, you will be able to remove the door.
7. Remove the fixing screw on the door handle, then remove the handle and fix it on the right of the door.
8. Tear off the PVC cover of the top control panel.
9. Remove the five screws and take off the plastic panel.
10. Remove the upper door axis, axis jacket and install them to the left, then tighten the screw.
11. Install the plastic panel and tighten the screws.
12. Recover the new PVC cover packed in the accessory kit.
13. Install the door.
14. Install the left downward hinge (in the accessory kit) and install the right downward hinge cover.
15. Install the door support on the place of the right downward hinge and then affix the cover.
16. You now have the door fully installed on your desired side.

Note: Please do not power up the unit for 48 hours to allow the coolants to settle inside the compressor.

Additional instructions for door handle installation:

1. Gently pull away the door gasket in the area where the handle is to be installed. The gasket is easily displaced by hand; no tools are necessary.
2. Use a Phillips head screwdriver to remove/install screws securing door handle. (Do not over tighten screws as this will cause damage to the handle.)
3. If needed, use a flat head screwdriver to remove the 2 decorative plugs from the front of the door or the plugs at the top of the door where the hinge is located, if they are located on the side you wish the handle to be installed on. Save the plugs for future use.
4. Replace the door gasket to its original position. Insert plugs into open door holes if desired.

CLEANING AND CARE

- Always unplug the wine cellar before cleaning.
- Do not use benzene, scrubbing brushes or chemical cleaners as these will damage the unit.
- Use only a mild, nonabrasive cleanser to clean the exterior of the cabinet.
- Clean the stainless steel door and handle by wiping with a warm water and baking soda solution. The solution should be about 2 tablespoons of baking soda to a quart of water.
- Wash the racks with a mild detergent solution.
- Always dry all parts with a clean, dry cloth before plugging the wine cellar back into the receptacle.

MOVING YOUR WINE CELLAR

- Always unplug the wine cellar before moving.
- Remove all bottles before moving the wine cellar.
- Securely tape down all loose items (shelves) inside your appliance.
- Turn the leveling legs up to the base to avoid damage.
- Tape the door shut.
- Be sure the wine cellar stays in the upright position during transportation
- Protect the outside of appliance with a blanket or similar item when moving as needed.

TROUBLESHOOTING

You can solve many common wine cellar problems easily, saving you the cost of a possible service call. Try the suggestion below to see if you can solve the problem before contacting Vinotemp at info@vinotemp.com.

SYMPTOM	POSSIBLE CAUSE
Door will not close properly.	<ul style="list-style-type: none"> • The wine cellar is not level. • The shelves are out of position. • The door was reversed and not properly installed. • The door gasket is dirty. • A bottle in the cellar is too long.
Unit does not operate—does not have power	<ul style="list-style-type: none"> • Check that unit is plugged into the wall socket. • Make sure the wall socket has power. If outlet is controlled by a wall switch, make sure switch is set to on. Test wall socket functionality by testing another electrical appliance in the power socket.
Power is ON but the unit will not cool.	<ul style="list-style-type: none"> • Make sure there are at least 3 to 5 bottles in the unit. When using the unit for the first time, it can take up to 24 hours to reach the desired temperature. • If the room temperature is above 90°F (32°C), the unit will not get below 51°F (11°C). Humidity does not affect the cooling ability of the unit. • To achieve accurate temperature control, the unit should not be used or operated in any of the following locations: <ul style="list-style-type: none"> ○ In a sunny place ○ In a room with poor air circulation such as a garage near another heat-producing appliance such as a dishwasher, oven or refrigerator. ○ With an outlet shared with a refrigerator, as the refrigerator will drain power from the wine cellar. ○ In a cabinet or closet. • Make sure the cooling vents are not obstructed.
Fan is always running.	<ul style="list-style-type: none"> • This is simply a function of the cooling system. The lower the setting, the more the fan will run. If the room is warmer than 90°F (32°C), it will run more. • The unit has been designed to run continuously when operating at the lower temperatures.
Vibrations	<ul style="list-style-type: none"> • Check to make sure the wine cellar is level.

TERMS OF SALE AND WARRANTY

Vinotemp International ("Seller") and the person or entity that acquires these goods from Seller ("Purchaser") hereby fully agree to the following terms and conditions of the sale: Shipping fees are the responsibility of the Purchaser whether freight prepaid or freight collect. Seller assumes no responsibility for the goods sold to the Purchaser once the goods have left the Seller's premises, including, but not limited to, late delivery by the moving carrier, or for events caused by any difficulty carrier incurs in attempting to fit the goods into the Purchaser's place of business or residence due to the size of the goods or otherwise. Purchaser assumes all responsibility for delivery, payment of freight, access, measurement, installation, hook-up, wiring, moving and storage of the goods. The transportation of all goods is subject to the terms and conditions which the moving carrier imposes on Purchaser including, but not limited to, additional charges imposed per flight of stairs, and/or additional charges resulting from the carrier's inability to safely and/or adequately use the building elevator to lift the goods to an upper floor. Any claim for damages incurred during shipment by the carrier of the goods are insured and handled directly with the carrier. Any damages due to manufacture defects will be handled directly with Vinotemp International, subject to the limited warranty.

All sales are final, and unless authorized in writing by the Seller, Purchaser may not return the goods, under any circumstance. If Purchaser refuses to accept the goods, under any circumstance, the Purchaser is liable for the return and cost of freight both ways, and if Seller does take back the goods, there will be a restocking charge that is 35% of the purchase price of the goods. Purchaser must notify Seller of non-conforming goods within four days of delivery, after which time all goods are deemed accepted.

If Purchaser tenders payment with a check that has insufficient funds (NSF), or stops payment on a check or credit card for any reason, Purchaser agrees to pay for all costs associated with the Seller's connection or litigation of such a claim, including without limitation extra damages, court costs and attorneys' fees. Finance charges begin the date of invoice. Collection fees plus NSF fee of 50\$ will be added to your invoice, which you agree to promptly pay. Title to the goods does not pass until payment is received in full by Seller and Seller retains a security interest in the goods until they are paid for in full.

LIMITED WARRANTY: Seller warrants that the goods will be free of defects in materials and workmanship as follows: Metal cabinet wine, beverage, refrigerator and freezer units: parts and labor for cooling system and cabinetry for a period of 12 (twelve) months from date of sale, removal and re-installation of unit is not included in warranty. For a scratch and dent or refurbished unit, warranty is 3 months from your dated invoice (parts for function only, not cosmetic). There is no warranty on parts purchased separately. Purchaser's exclusive remedy is limited, at Seller's option; to repair or replace defective part[s] with either new or factory reconditioned part[s]. Purchaser is responsible for shipping the unit pre-paid to designated facility and Seller will pay return shipping charges in the continental United States for items repaired under warranty within 12 months from date of sale. Improper placement of the unit will void the warranty. This limited warranty does not cover damage due to such things as accident, misuse, abuse, mishandling, neglect, acts of God, fires, earthquakes, floods, high winds, government, war, riot or labor trouble, strikes, lockouts, delay of carrier, unauthorized repair, or any other cause beyond the control of the Seller, whether similar or dissimilar to the foregoing. Seller is not responsible for any damages caused to Seller's property resulting from the good. This limited warranty applies only inside the Continental US. (Alaska, Puerto Rico and Hawaii are not warranted).

Purchaser understands and acknowledges that the goods sold here are wine cellars and/or other similar units which house wine. Purchaser assumes all risk of using these units, including risk of spoilage, humidity variations, temperature variations, leaks, fire, water damage, mold, mildew, dryness and similar and any other perils that might occur.

Seller is not responsible for incidental or consequential damages, and there are no warranties, expressed or implied, which extend beyond the Limited Warranty described above. The implied warranties of merchantability and of fitness for a particular purpose are hereby expressly disclaimed. Some states do not allow the exclusion of incidental or consequential damages, or a waiver of the implied warranties of fitness and/or merchantability, so the above limitations may not apply to you. This warranty gives you specific legal rights and you may also have other rights which vary from state to state.

In the event of any dispute between Seller and Purchaser arising out of or relating to these terms and conditions or to the goods sold generally, Purchaser must first file a written claim with Seller within ten days of the occurrence giving rise to the claim and wait an additional thirty days for a response before initiating any legal action. The sale and all terms are subject to California law. Any legal proceeding arising out of or relating to these terms and conditions or to the goods sold generally shall be brought solely and exclusively in the County of Los Angeles. In no event may Purchaser initiate any legal proceeding more than six months after the occurrence of the event giving rise to the dispute.

The above terms and conditions are the only ones governing this transaction and Seller makes no oral representations of any kind. These Terms and Conditions can only be modified in writing, signed by both Purchaser and Seller. 07/08

SERVICE & IMPORTANT NOTICE

Upon receipt and inspection of unit, the supply cord must be replaced if it is damaged. Contact our customer service at 1-800-777-8466 or info@vinotemp.com.

The manufacturer has a policy of continuous improvement on its products and reserves the right to change materials and specifications without notice.

WARNING

**Please do not place the unit within reach of children.
For adult use only.**

contact info@vinotemp.com with any questions or visit:

www.vinotemp.com



17631 S. Susana Road
Rancho Dominguez, CA 90221
www.vinotemp.com

Vinotemp is a registered trademark of Vinotemp International. All products, features, and services are subject to change without notice. We cannot guarantee the accuracy of the contents of this document. We disclaim liability for errors, omissions, or future changes.

© 2008 Vinotemp International. All rights reserved.