

Vinotemp®

A PROUD HERITAGE OF EXPERIENCE & QUALITY



WINE COOLER

VT-12TEDI (12 BOTTLE)

OWNER'S MANUAL



WWW.VINOTEMP.COM

YOUR WINE CELLAR

This unit can be used for Storage and/or Service. The unit has a glass door and soft interior light that you can leave on to elegantly display your wine.

SERVING WINES

Storing wines at the proper temperature is important. To preserve them as long as possible wine should be stored at approximately 55° Fahrenheit. However, the chart below suggests the optimal drinking temperature for the different styles of wine.

°C	°F	Wine Style
19	66	Armagnac, Brandy, Cognac
18	64.5	Full Bodied Red wines, Shiraz
17	62	Tawny Port
15	59	Medium Bodied Red Wines
14	57	Amontillado Sherry
13	55.5	Light Bodied Red Wines
12	53.5	Full Bodied White Wines
11	52	Medium Bodied White Wines
10	50	Rosé, Light Bodied White Wines
9	48	Vintage Sparkling
8	53.5	Fino Sherry
7	44.5	Non Vintage Sparkling

General Operating Instructions

Remove all packaging and labels from your wine cellar. Be sure that all parts have been included before discarding any packaging materials. You may want to keep the box and packing materials for use at a later date.

Upon receipt and inspection of unit, the supply cord must be replaced if it is damaged. Contact our customer service at 1-800-777-8466 or info@vinotemp.com.

- Please fully read the instruction manual.

**Please read and follow all safety rules
and operating instructions before using.**

Table of Contents

Cabinet and Circuit Diagram	6
Technical Data	7
Important Safety Instructions.....	8
Installing Your Wine Cellar	9
Electrical Connection	10
Important Safeguards.....	10
Operating Your Wine Cellar	12
Care and Maintenance	12
Maintenance Of Your Wine Cellar	12
Problems With Your Wine Cellar: Troubleshooting Guide	13
Terms Of Sale and Warranty	14
Service & Important Notice	15
Contact Information	15

Cabinet Diagram

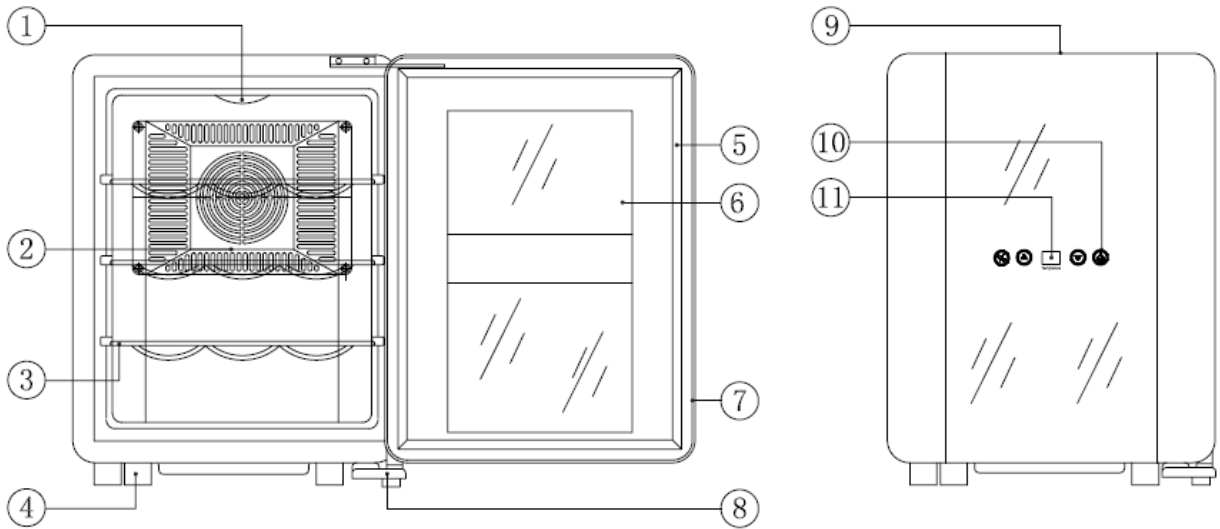

- | | |
|------------------|-------------------------------|
| 1. LIGHT | 7. DOOR FRAME |
| 2. FAN MASK | 8. REAM COVER |
| 3. SHELF | 9. DOOR HANDLE |
| 4. FOOT | 10. LIGHT SWITCH |
| 5. MAGNETIC SEAL | 11. TEMPERATURE CONTROL PANEL |
| 6. GLASS | |

Circuit Diagram

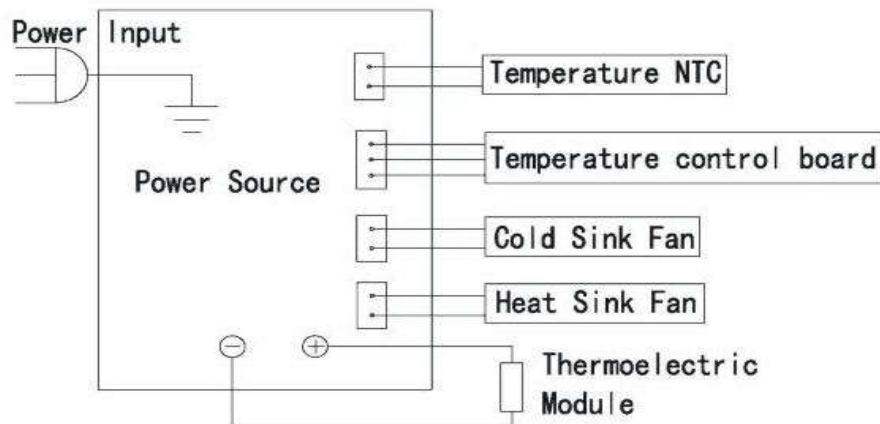

Technical Data

Model no.	VT-12TEDI
Capacity	12 Bottles
Voltage	100-120V AC
Current	1A (77°F/25°C)
Protection class	I
Frequency	60HZ
Climate class	SN;N
Input power	70W (77°F/25°C)
Power Consumption kWh/24h	1.0 (59°F/15°C)
Temperature Control Range	50-66°F (10-18°C)
Net weight	25.4 Lbs (11.5 Kgs)
Gross weight	29.8 Lbs (13.5 Kgs)
Unit size (W×H×D)	13.5"x19"x19.75"
Packing size (W×H×D)	17.32"x22.56"x23.5"

IMPORTANT SAFETY INSTRUCTIONS

⚡ WARNING ⚡

To reduce the risk of fire, electrical shock or injury when using your appliance, follow these basic precautions:

- Read all instructions before using the wine cellar.
- **DANGER** or **WARNING**: Risk of child entrapment.
- Junked or abandoned appliances are dangerous...even if they "just sit in the garage a few days."
- **Before you throw away your old wine cellar:** Take off the door and leave the shelves in place so that children may not easily climb inside.
- Never allow children to operate, play with, or crawl inside the appliance.
- Never clean appliance parts with flammable fluids. The fumes can create a fire hazard or explosion.
- Do not store or use gasoline or any other flammable vapors and liquids in the vicinity of this or any other appliance. The fumes can create a fire hazard or explosion.

-Save these instructions-

INSTALLATION INSTRUCTIONS

Before using your wine cellar

- Remove the exterior and interior packing
- Check to be sure the following parts are included:
 - For VT-12TEDi, 3 Slide out shelves
 - 1 Instruction manual
- Before connecting the appliance to the power source, let it stand upright for approximately 2 hours. This will reduce the possibility of a malfunction in the cooling system from handling during transportation.
- Clean the interior surface with lukewarm water using a soft cloth.

INSTALLING YOUR WINE CELLAR

- Place your appliance on a floor that is strong enough to support the appliance when it is fully loaded. To level your appliance, adjust the front legs at the bottom of the appliance.
- Unit must be placed as a freestanding unit—not to be built in.
- For proper installation, keep away from direct sunlight and sources of heat (stove, heater, radiator, etc.). Direct sunlight may affect the coating and heat sources may increase electrical consumption. Extreme cold or hot ambient temperatures may also cause the appliances not to perform properly.
- Not designed for placement in garage or basement. Designed for use inside the home.

ELECTRICAL CONNECTION

⚡ WARNING ⚡

Improper use of the grounded plug can result in the risk of electrical shock. If the power cord is damaged, have it replaced by an authorized products service center.

This unit should be properly grounded for your safety. The power cord of this unit is equipped with a 3-pin plug which mates with 3-pin wall outlets to minimize the possibility of electrical shock. Do not under any circumstances cut or remove the ground wire from the power cord supplied.

Don't use extension cords.

This unit requires a standard 100-120V—60HZ electrical outlet with 3-pin plug.

The cord should be secured behind the wine cellar and not exposed or dangling to prevent accidental injury.

IMPORTANT SAFEGUARDS

When using an electrical appliance, basic precautions should always be followed, including the following:

READ ALL INSTRUCTIONS BEFORE USING THIS WINE COOLER

- Do not use if supply cord is damaged. If damaged, it must be replaced by the manufacturer or a similarly qualified person in order to avoid hazard.
- This wine cooler is not intended for use by young children or infirm persons, without supervision. Young children must be supervised to ensure they do not play with the appliance.
- Ensure the cooler is unplugged before cleaning.
- To clean the cooler, use only mild detergents or glass cleaning products. Do not use harsh detergents or solvents.
- It is not recommended to use this wine cooler with an extension cord or power board. Please ensure that the appliance is plugged directly into the electrical outlet.

- When positioning the wine cooler, ensure that there is at least a 5cm (2 inch) clearance at the sides and a 10cm (4 inch) clearance at the back of the cooler as this is the main outlet for heat. This will allow for adequate ventilation.
- Unit must be freestanding; cannot be used as a built-in cooler.
- This cooler is designed to store wine bottles. It is not intended for food.
- Do not place hot food or drink into the wine cooler before it cools down to room temperature.
- Close the cooler door immediately after putting in any items so the inside temperature will not rise dramatically.
- Keep appliance away from any heat source or direct sunlight.
- For stability, the appliance must be placed on a solid, flat surface. It should not be laid on any soft material.
- Do not place any other appliance on top of the wine cooler.
- The wine cooler is an electrical appliance. To avoid injury or death from electrical shock, do not operate the wine cooler with wet hands, while standing on a wet surface or while standing in water.
- Do not use outdoors or in wet conditions.
- When positioned or if moving the appliance, ensure that it is not set horizontally, positioned at an angle of more than 45°, or turned upside down.
- Never lift or carry the wine cooler by the cord.
- Keep the cord away from heated surfaces.
- This wine cooler is for household use only. Any other use will void the warranty.
- Do not plug into the power socket before set up is completed.
- Always unplug an appliance from outlet when not in use. Never pull cord to remove plug from outlet. Grasp plug and pull to disconnect.
- An empty cooler can be a dangerous attraction to children. If disposing of the cooler, remove gaskets, latches, lids or the entire door from your unused appliance, or take other action to ensure the cooler is harmless.

OPERATING YOUR WINE CELLAR

It is recommended that you install the wine cellar in a place where the ambient temperature is between 50°F and 80°F. If the ambient temperature is above or below recommended temperature, the performance of the unit may be affected. For example, placing in extreme cold or hot conditions may cause interior temperature to fluctuate. Internal range of 50-66°F may not be reached. The temperature may fluctuate depending on whether or not the interior light is on or off or whether the bottles are located on the upper, middle or lower section.

How to use the buttons on the Display Panel:

You can set the temperature as your desire by pressing the control panel buttons. There are two buttons on the panel "▲" and "▼" to adjust the temperature by 1°F between 50-66 °F. You can turn the interior light on or off by pressing the "⏻" button.

CARE AND MAINTENANCE

Cleaning your wine cellar

- Unplug the wine cellar and remove the bottles and shelves.
- Wash the inside with warm water or a baking soda solution. The solution should be about 2 tablespoons of baking soda to a quart of water.
- The outside of the wine cellar should be cleaned with mild detergent and warm water.

MAINTENANCE OF YOUR WINE CELLAR

Moving your wine cellar

- Remove all the bottles and shelves.
- Securely tape down all loose items inside your wine cellar.
- Turn the leveling legs up to the base to avoid damage.
- Tape the door shut.
- Be sure the wine cellar stays in the upright position during transportation.

PROBLEMS WITH YOUR WINE CELLAR

You can solve many common wine cellar problems easily, saving you the cost of a possible service call. Try the suggestion below to see if you can solve the problem before contacting Vinotemp at info@vinotemp.com

TROUBLESHOOTING GUIDE

PROBLEM	POSSIBLE CAUSE
Wine cellar does not operate	<ul style="list-style-type: none"> • Not plugged in • Using wrong voltage • The circuit breaker tripped • Blown fuse.
Wine cellar is not cold enough	<ul style="list-style-type: none"> • Check the temperature control setting, external environment may require a cooler setting. • The door is open too often. • The door is not closed completely. • The door seal does not seal properly. • The wine cellar does not have the correct clearance at the back and two sides.
Light does not work	<ul style="list-style-type: none"> • Call the service center.
Vibrations	<ul style="list-style-type: none"> • Check to see that the wine cellar is level.
Wine cellar seems to make too much noise	<ul style="list-style-type: none"> • The wine cellar is not level. • Check the fans inside the cabinet and at the back of the unit
Door will not close properly	<ul style="list-style-type: none"> • The wine cellar is not level. • The seal is weak. • The shelves are out of position.
Temperature LED does not display	<ul style="list-style-type: none"> • Main control board does not work. • Temperature controller problem. • There is some problem with the plug (no power supply)
Temperature LED display error	<ul style="list-style-type: none"> • Temperature sensor is cut off.
Buttons are not functional	<ul style="list-style-type: none"> • Temperature controller panel is damaged.
Supply cord is damaged	<ul style="list-style-type: none"> • Cord must be replaced by the manufacturer, its service agent or a similarly qualified person in order to avoid a hazard

TERMS OF SALE AND WARRANTY

Vinotemp International ("Seller") and the person or entity that acquires these goods from Seller ("Purchaser") hereby fully agree to the following terms and conditions of the sale: Shipping fees are the responsibility of the Purchaser whether freight prepaid or freight collect. Seller assumes no responsibility for the goods sold to the Purchaser once the goods have left the Seller's premises, including, but not limited to, late delivery by the moving carrier, or for events caused by any difficulty carrier incurs in attempting to fit the goods into the Purchaser's place of business or residence due to the size of the goods or otherwise. Purchaser assumes all responsibility for delivery, payment of freight, access, measurement, installation, hook-up, wiring, moving and storage of the goods. The transportation of all goods is subject to the terms and conditions which the moving carrier imposes on Purchaser including, but not limited to, additional charges imposed per flight of stairs, and/or additional charges resulting from the carrier's inability to safely and/or adequately use the building elevator to lift the goods to an upper floor. Any claim for damages incurred during shipment by the carrier of the goods are insured and handled directly with the carrier and must be noted at time of delivery. Any damages due to manufacture defects will be handled directly with Vinotemp International, subject to the limited warranty.

All sales are final, and unless authorized in writing by the Seller, Purchaser may not return the goods, under any circumstance. If Purchaser refuses to accept the goods, under any circumstance, the Purchaser is liable for the return and cost of freight both ways, and if Seller does take back the goods, there will be a restocking charge that is 35% of the purchase price of the goods. (Product must be in original packaging). Built-to-Order products (including Cabinets, Racking, and Accessories) are non-returnable.

Purchaser must notify Seller of non-conforming goods within four days of delivery, after which time all goods are deemed accepted. If an order has been placed and production has started, cancellation of your order will be a 15% charge.

If Purchaser tenders payment with a check that has insufficient funds (NSF), or stops payment on a check or credit card for any reason, Purchaser agrees to pay for all costs associated with the Seller's collection or litigation of such a claim, including without limitation extra damages, court costs and attorneys' fees. Finance charges begin the date of invoice. Collection fees plus NSF fee of \$50 will be added to your invoice, which you agree to promptly pay. Title to the goods does not pass until payment is received in full by Seller and Seller retains a security interest in the goods until they are paid for in full.

LIMITED WARRANTY: Seller warrants that the goods will be free of defects in materials and workmanship as follows: Furniture style (wood) wine cabinets: all cooling unit parts for a period of 5 (five) years; cabinetry and labor (uninstalled) for a period of 12 (twelve) months from date of sale. For the metal cabinet wine units: parts and labor for cooling system and cabinetry for a period of 12 (twelve) months from date of sale. Thermoelectric Units: 90 (ninety) days from the date of sale (including Wine Coolers, Beer Dispensers, Humidor, Portofino Wood Cellars, and Refrigerators). Wine-Mate Split Systems and installed products are parts only for 1 year, no labor. Other Wine-Mate Cooling Systems are 5 years parts, 1 year labor. Wine Accessories and Racking Systems are not warranted. For a scratch and dent/refurbished unit, warranty is 3 months from your dated invoice (parts for function only, not cosmetic). There is no warranty on parts purchased separately. Removal and re-installation of unit is not included in warranted labor. Purchaser's exclusive remedy is limited, at Seller's option; to repair or replace defective part[s] with either new or factory reconditioned part[s]. Purchaser is responsible for shipping the unit pre-paid to designated facility and Seller will pay return shipping charges in the continental United States for items repaired under warranty within 12 (twelve) months from date of sale. Since the natural variation in texture, density, grain, color, tone and shade of wood is unavoidable; Seller does not guarantee the texture, color, tone or shade of the wood: nor does seller guarantee the colorfastness of wood or against peeling, chipping, cracking or scratching. Note: Unfinished wood is subject to warping; all wood surfaces must be sealed before placing cellar into service. Improper placement of the unit will void the warranty. By Vinotemp in writing, any third party repair facility must be pre-approved before providing parts free of charge. This limited warranty does not cover damage due to such things as accident, misuse, abuse, mishandling, neglect, acts of God, fires, earthquakes, floods, high winds, government, war, riot or labor trouble, strikes, lockouts, delay of carrier, unauthorized repair, or any other cause beyond the control of the Seller, whether similar or dissimilar to the foregoing. Seller is not responsible for any damages caused to Purchaser's property resulting from the good. This limited warranty applies only inside the Continental US. (Alaska, Puerto Rico and Hawaii are not warranted.)

Purchaser understands and acknowledges that the goods sold here are wine cellars, cigar humidors, and/or other similar units which house wine or cigars. Purchaser assumes all risk of using these units, including risk of spoilage, humidity variations, temperature variations, leaks, fire, water damage, mold, mildew, dryness and similar and any other perils that might occur.

Seller is not responsible for incidental or consequential damages, and there are no warranties, expressed or implied, which extend beyond the Limited Warranty described above. The implied warranties of merchantability and of fitness for a particular purpose are hereby expressly disclaimed. Some states do not allow the exclusion of incidental or consequential damages, or a waiver of the implied warranties of fitness and/or merchantability, so the above limitations may not apply to you. This warranty gives you specific legal rights and you may also have other rights which vary from state to state.

In the event of any dispute between Seller and Purchaser arising out of or relating to these terms and conditions or to the goods sold generally, Purchaser must first file a written claim with Seller within ten days of the occurrence giving rise to the claim and wait an additional thirty days for a response before initiating any legal action. The sale and all terms are subject to California law. Any legal proceeding arising out of or relating to these terms and conditions or to the goods sold generally shall be brought solely and exclusively in the County of Los Angeles. In no event may Purchaser initiate any legal proceeding more than six months after the occurrence of the event giving rise to the dispute.

The above terms and conditions are the only ones governing this transaction and Seller makes no oral representations of any kind. These Terms and Conditions can only be modified in writing, signed by both Purchaser and Seller. 10/10

SERVICE & IMPORTANT NOTICE

Upon receipt and inspection of unit, the supply cord must be replaced if it is damaged. Contact our customer service at 1-800-777-8466 or info@vinotemp.com.

The Manufacturer has a policy of continuous improvement on its products and reserves the right to change materials and specifications without notice.

WARNING

**Please do not place the unit within reach of children.
For adult use only.**

Contact **info@vinotemp.com** with any questions or visit:

www.vinotemp.com



17621 S. Susana Road
Rancho Dominguez, CA 90221
www.vinotemp.com

Vinotemp is a registered trademark of Vinotemp International. All products, features, and services are subject to change without notice. We cannot guarantee the accuracy of the contents of this document. We disclaim liability for errors, omissions, or future changes.

© 2008 Vinotemp International. All rights reserved.